

AP[®] Physics C: Mechanics

Practice Exam

The questions contained in this AP[®] Physics C: Mechanics Practice Exam are written to the content specifications of AP Exams for this subject. Taking this practice exam should provide students with an idea of their general areas of strengths and weaknesses in preparing for the actual AP Exam. Because this AP Physics C: Mechanics Practice Exam has never been administered as an operational AP Exam, statistical data are not available for calculating potential raw scores or conversions into AP grades.

This AP Physics C: Mechanics Practice Exam is provided by the College Board for AP Exam preparation. Teachers are permitted to download the materials and make copies to use with their students in a classroom setting only. To maintain the security of this exam, teachers should collect all materials after their administration and keep them in a secure location. Teachers may not redistribute the files electronically for any reason.

Contents

Directions for Administration	ii
Section I: Multiple-Choice Questions	1
Section II: Free-Response Questions	14
Student Answer Sheet for Multiple-Choice Section	22
Multiple-Choice Answer Key	23
Free-Response Scoring Guidelines	24

The College Board: Connecting Students to College Success

The College Board is a not-for-profit membership association whose mission is to connect students to college success and opportunity. Founded in 1900, the association is composed of more than 5,000 schools, colleges, universities, and other educational organizations. Each year, the College Board serves seven million students and their parents, 23,000 high schools, and 3,500 colleges through major programs and services in college admissions, guidance, assessment, financial aid, enrollment, and teaching and learning. Among its best-known programs are the SAT[®], the PSAT/NMSQT[®], and the Advanced Placement Program[®] (AP[®]). The College Board is committed to the principles of excellence and equity, and that commitment is embodied in all of its programs, services, activities, and concerns.

Visit the College Board on the Web: www.collegeboard.com.

AP Central is the official online home for the AP Program: apcentral.collegeboard.com.

AP[®] Physics C: Mechanics Directions for Administration

The AP Physics C: Mechanics Exam is one and one-half hours in length and consists of a multiple-choice section and a free-response section.

- The 45-minute multiple-choice section contains 35 questions and accounts for 50 percent of the final grade.
- The 45-minute free-response section contains 3 questions and accounts for 50 percent of the final grade.

Students should be given a 10-minute warning prior to the end of each section of the exam. A 10-minute break should be provided after Mechanics is completed if students are taking Physics C: Electricity and Magnetism immediately after Mechanics.

The actual AP Physics C Exams are administered in one session, Mechanics first followed by Electricity and Magnetism. Students taking only one of the exams will have the most realistic experience if both sections are completed in one session. Similarly, students taking both Physics C exams will have the most realistic experience if both exams are completed in one session and a complete morning or afternoon is available to administer them. If a schedule does not permit one time period for administration, it would be acceptable to administer Mechanics on one day and Electricity and Magnetism on a subsequent day, or to further break things up and administer Section I and Section II of each exam on subsequent days.

Many students wonder whether or not to guess the answers to the multiple-choice questions about which they are not certain. It is improbable that mere guessing will improve a score. However, if a student has some knowledge of the question and is able to eliminate one or more answer choices as wrong, it may be to the student's advantage to answer such a question.

- The use of calculators is permitted only on Section II. Straightedges or rulers are allowed on both parts of the exam.
- It is suggested that the practice exam be completed using a pencil to simulate an actual administration.
- Teachers will need to provide paper for the students to write their free-response answers. Teachers should provide directions to the students indicating how they wish the responses to be labeled so the teacher will be able to associate the student's response with the question the student intended to answer.
- The 2008–2009 AP Physics C table of information is included as a part of Section I. The table and the AP Physics C equation lists are included with Section II. The equation lists are not allowed for Section I. If you use these exams in subsequent years you should download the newer versions of the table and lists from AP Central.
- Remember that students are not allowed to remove any materials, including scratch work, from the testing site.

Section I

Multiple-Choice Questions

TABLE OF INFORMATION FOR 2008 and 2009

CONSTANTS AND CONVERSION FACTORS	
Proton mass, $m_p = 1.67 \times 10^{-27}$ kg	Electron charge magnitude, $e = 1.60 \times 10^{-19}$ C
Neutron mass, $m_n = 1.67 \times 10^{-27}$ kg	1 electron volt, $1 \text{ eV} = 1.60 \times 10^{-19}$ J
Electron mass, $m_e = 9.11 \times 10^{-31}$ kg	Speed of light, $c = 3.00 \times 10^8$ m/s
Avogadro's number, $N_0 = 6.02 \times 10^{23}$ mol ⁻¹	Universal gravitational constant, $G = 6.67 \times 10^{-11}$ m ³ /kg·s ²
Universal gas constant, $R = 8.31$ J/(mol·K)	Acceleration due to gravity at Earth's surface, $g = 9.8$ m/s ²
Boltzmann's constant, $k_B = 1.38 \times 10^{-23}$ J/K	
1 unified atomic mass unit,	$1 \text{ u} = 1.66 \times 10^{-27}$ kg = $931 \text{ MeV}/c^2$
Planck's constant,	$h = 6.63 \times 10^{-34}$ J·s = 4.14×10^{-15} eV·s
	$hc = 1.99 \times 10^{-25}$ J·m = 1.24×10^3 eV·nm
Vacuum permittivity,	$\epsilon_0 = 8.85 \times 10^{-12}$ C ² /N·m ²
Coulomb's law constant, $k = 1/4\pi\epsilon_0 = 9.0 \times 10^9$ N·m ² /C ²	
Vacuum permeability,	$\mu_0 = 4\pi \times 10^{-7}$ (T·m)/A
Magnetic constant, $k' = \mu_0/4\pi = 10^{-7}$ (T·m)/A	
1 atmosphere pressure,	$1 \text{ atm} = 1.0 \times 10^5$ N/m ² = 1.0×10^5 Pa

UNIT SYMBOLS	meter,	m	mole,	mol	watt,	W	farad,	F
	kilogram,	kg	hertz,	Hz	coulomb,	C	tesla,	T
	second,	s	newton,	N	volt,	V	degree Celsius,	°C
	ampere,	A	pascal,	Pa	ohm,	Ω	electron-volt,	eV
	kelvin,	K	joule,	J	henry,	H		

PREFIXES		
Factor	Prefix	Symbol
10 ⁹	giga	G
10 ⁶	mega	M
10 ³	kilo	k
10 ⁻²	centi	c
10 ⁻³	milli	m
10 ⁻⁶	micro	μ
10 ⁻⁹	nano	n
10 ⁻¹²	pico	p

VALUES OF TRIGONOMETRIC FUNCTIONS FOR COMMON ANGLES							
θ	0°	30°	37°	45°	53°	60°	90°
$\sin \theta$	0	1/2	3/5	$\sqrt{2}/2$	4/5	$\sqrt{3}/2$	1
$\cos \theta$	1	$\sqrt{3}/2$	4/5	$\sqrt{2}/2$	3/5	1/2	0
$\tan \theta$	0	$\sqrt{3}/3$	3/4	1	4/3	$\sqrt{3}$	∞

The following conventions are used in this exam.

- I. Unless otherwise stated, the frame of reference of any problem is assumed to be inertial.
- II. The direction of any electric current is the direction of flow of positive charge (conventional current).
- III. For any isolated electric charge, the electric potential is defined as zero at an infinite distance from the charge.

PHYSICS C: MECHANICS

SECTION I

Time—45 minutes

35 Questions

Directions: Each of the questions or incomplete statements below is followed by five suggested answers or completions. Select the one that is best in each case and place the letter of your choice in the corresponding box on the student answer sheet.

Note: To simplify calculations, you may use $g = 10\text{ m/s}^2$ in all problems.

1. Which of the following graphs of position d versus time t corresponds to motion of an object in a straight line with positive acceleration?

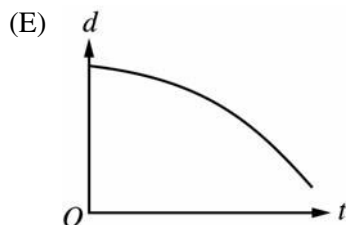
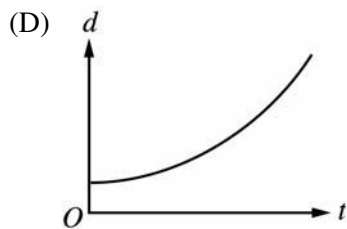
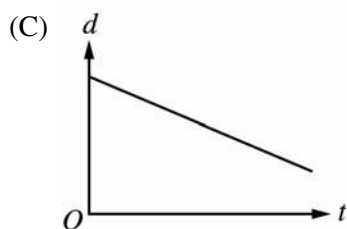
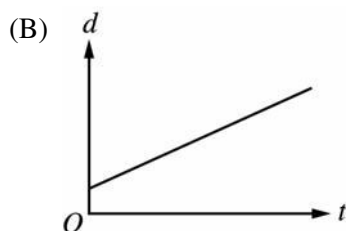
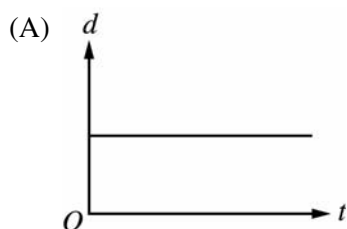

2. A ball is thrown straight up from a point 2 m above the ground. The ball reaches a maximum height of 3 m above its starting point and then falls 5 m to the ground. When the ball strikes the ground, what is its displacement from its starting point?

- (A) Zero
 (B) 8 m below
 (C) 5 m below
 (D) 2 m below
 (E) 3 m above

3. What do acceleration and velocity have in common?

- (A) Both are scalars.
 (B) Both are vectors.
 (C) Both are measured in units of distance divided by time.
 (D) Both are measured in units of distance divided by time squared.
 (E) They are different names for the same quantity.

4. Two projectiles are launched with the same initial speed from the same location, one at a 30° angle and the other at a 60° angle with the horizontal. They land at the same height at which they were launched. If air resistance is negligible, how do the projectiles' respective maximum heights, H_{30} and H_{60} , and times in the air, T_{30} and T_{60} , compare with each other?

	<u>Maximum Height</u>	<u>Time in Air</u>
(A)	$H_{30} > H_{60}$	$T_{30} > T_{60}$
(B)	$H_{30} > H_{60}$	$T_{30} < T_{60}$
(C)	$H_{30} = H_{60}$	$T_{30} = T_{60}$
(D)	$H_{30} < H_{60}$	$T_{30} > T_{60}$
(E)	$H_{30} < H_{60}$	$T_{30} < T_{60}$

GO ON TO THE NEXT PAGE.

5. An object of mass 100 kg is initially at rest on a horizontal frictionless surface. At time $t = 0$, a horizontal force of 10 N is applied to the object for 1 s and then removed. Which of the following is true of the object at time $t = 2$ s if it is still on the surface?

- (A) It is at the same position it had at $t = 0$, since a force of 10 N is not large enough to move such a massive object.
- (B) It is moving with constant nonzero acceleration.
- (C) It is moving with decreasing acceleration.
- (D) It is moving at a constant speed.
- (E) It has come to rest some distance away from the position it had at $t = 0$.

6. Several forces act on an object, but the object is in equilibrium. Which of the following statements about the object must be true?

- I. It has zero acceleration.
- II. The net force acting on it is zero.
- III. It is at rest.
- IV. It is moving with constant velocity.

- (A) I and II
- (B) I and III
- (C) I and IV
- (D) II and III
- (E) II and IV

Questions 7-8

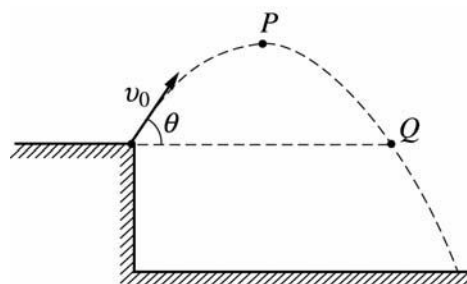

A rock is thrown from the edge of a cliff with an initial velocity v_0 at an angle θ with the horizontal as shown above. Point P is the highest point in the rock's trajectory and point Q is level with the starting point. Assume air resistance is negligible.

7. Which of the following correctly describes the horizontal and vertical speeds and the acceleration of the rock at point P ?

	<u>Horizontal Speed</u>	<u>Vertical Speed</u>	<u>Acceleration</u>
(A)	$v_0 \cos \theta$	0	g
(B)	0	0	g
(C)	$v_0 \cos \theta$	0	0
(D)	$v_0 \cos \theta$	$v_0 \sin \theta$	g
(E)	0	$v_0 \cos \theta$	0

8. Which of the following correctly describes the horizontal and vertical speeds and the acceleration of the rock at point Q ?

	<u>Horizontal Speed</u>	<u>Vertical Speed</u>	<u>Acceleration</u>
(A)	$v_0 \cos \theta$	0	g
(B)	0	0	g
(C)	$v_0 \cos \theta$	0	0
(D)	$v_0 \cos \theta$	$v_0 \sin \theta$	g
(E)	0	$v_0 \cos \theta$	0

GO ON TO THE NEXT PAGE.

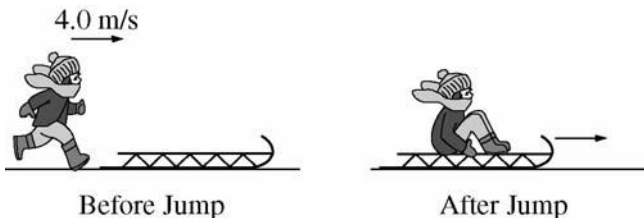

9. As shown in the figure above, a child of mass 20 kg who is running at a speed of 4.0 m/s jumps onto a stationary sled of mass 5.0 kg on a frozen lake. The speed at which the child and sled begin to slide across the ice is most nearly

- (A) 0.20 m/s
- (B) 0.80 m/s
- (C) 1.2 m/s
- (D) 3.2 m/s
- (E) 16 m/s

10. A toy spacecraft is launched directly upward. When the toy reaches its highest point, a spring is released and the toy splits into two parts with masses of 0.02 kg and 0.08 kg, respectively. Immediately after the separation, the 0.02 kg part moves horizontally due east. Air resistance is negligible. True statements about the 0.08 kg part include which of the following?

- I. It could move north immediately after the spring is released.
- II. It takes longer to reach the ground than does the 0.02 kg part.
- III. It strikes the ground farther from the launch point than does the 0.02 kg part.

- (A) None
- (B) I only
- (C) III only
- (D) I and II only
- (E) II and III only

11. A student initially stands on a circular platform that is free to rotate without friction about its center. The student jumps off tangentially, setting the platform spinning. Quantities that are conserved for the student-platform system as the student jumps include which of the following?

- I. Angular momentum
- II. Linear momentum
- III. Kinetic energy

- (A) I only
- (B) II only
- (C) I and II only
- (D) II and III only
- (E) I, II, and III

12. In an experiment with a simple pendulum, measurements of the period T of the pendulum are made for different values of its length L . When plotted on a graph, which of the following should result in a straight-line fit of the data?

- (A) \sqrt{T} versus L
- (B) T versus L
- (C) T versus L^2
- (D) T^2 versus L
- (E) T^2 versus L^2

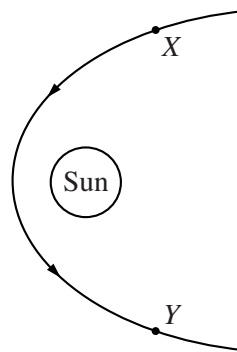

13. A comet moves in the Sun's gravitational field, following the path shown above. What happens to its angular momentum as it moves from point X to point Y?

- (A) It increases steadily.
- (B) It remains constant.
- (C) It decreases steadily.
- (D) It increases as it approaches the Sun and decreases as it moves away from the Sun.
- (E) It decreases as it approaches the Sun and increases as it moves away from the Sun.

GO ON TO THE NEXT PAGE.

14. Satellite X moves around Earth in a circular orbit of radius R . Satellite Y is also in a circular orbit around Earth, and it completes one orbit for every eight orbits completed by satellite X . What is the orbital radius of satellite Y ?

- (A) $\frac{1}{4}R$
- (B) $\frac{1}{2}R$
- (C) $2R$
- (D) $4R$
- (E) $8R$

15. A newly discovered planet is found to have twice the radius and five times the mass of Earth. If the acceleration of gravity at the surface of Earth is g , the acceleration of gravity at the surface of the new planet is

- (A) $\frac{2g}{5}$
- (B) $\frac{4g}{5}$
- (C) g
- (D) $\frac{5g}{4}$
- (E) $\frac{5g}{2}$

Questions 16-17

A toy car of mass 6 kg, moving in a straight path, experiences a net force given by the function $F = -3t$. At time $t = 0$, the car has a velocity of 4 m/s in the positive direction and is located +8 m from the origin.

16. The car will come instantaneously to rest at time t equal to

- (A) $\frac{2}{3}$ s
- (B) $\sqrt{\frac{4}{3}}$ s
- (C) $\sqrt{\frac{8}{3}}$ s
- (D) $\sqrt{8}$ s
- (E) 4 s

17. Which of the following best shows a graph of position d versus time t for the car?

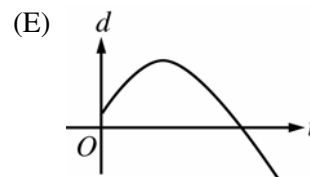
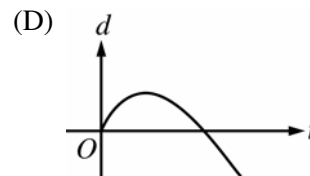
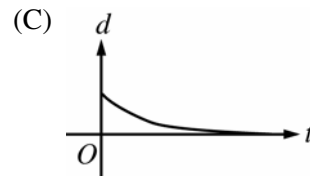
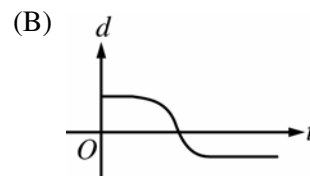
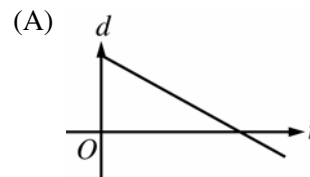

GO ON TO THE NEXT PAGE.

Questions 18-19

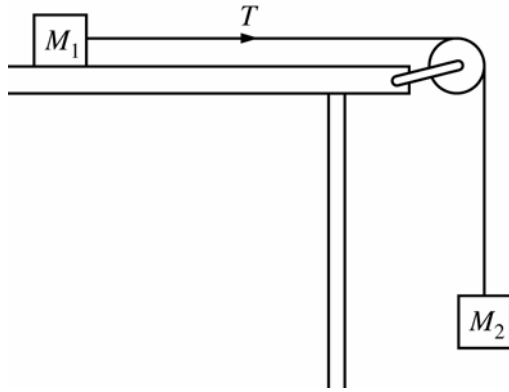

A block of mass M_1 on a horizontal table is connected to a hanging block of mass M_2 by a string that passes over a pulley, as shown above. The acceleration of the blocks is $0.6g$. Assume that friction and the mass of the string are negligible.

18. The tension T in the string is

- (A) zero
- (B) $0.4 M_2g$
- (C) $0.6 M_2g$
- (D) $1.0 M_2g$
- (E) $1.6 M_2g$

19. The ratio of masses M_2/M_1 is

- (A) 0.67
- (B) 1.0
- (C) 1.4
- (D) 1.5
- (E) 1.6

Questions 20-21

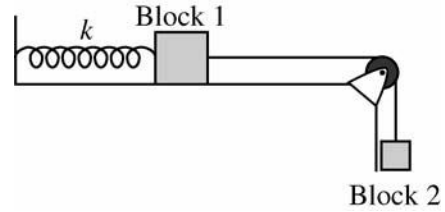

In the system of two blocks and a spring shown above, blocks 1 and 2 are connected by a string that passes over a pulley. The initially unstretched spring connects block 1 to a rigid wall. Block 1 is released from rest, initially slides to the right, and is eventually brought to rest by the spring and by friction on the horizontal surface.

20. Which of the following is true of the energy of the system during this process?

- (A) The total mechanical energy of the system is conserved.
- (B) The total mechanical energy of the system increases.
- (C) The energy lost to friction is equal to the gain in the potential energy of the spring.
- (D) The potential energy lost by block 2 is less in magnitude than the potential energy gained by the spring.
- (E) The potential energy lost by block 2 is greater in magnitude than the potential energy gained by the spring.

21. After block 1 comes to rest, the force exerted on it by the spring must be equal in magnitude to

- (A) zero
- (B) the frictional force on block 1
- (C) the vector sum of the forces on block 1 due to friction and tension in the string
- (D) the sum of the weights of the two blocks
- (E) the difference in the weights of the two blocks

GO ON TO THE NEXT PAGE.

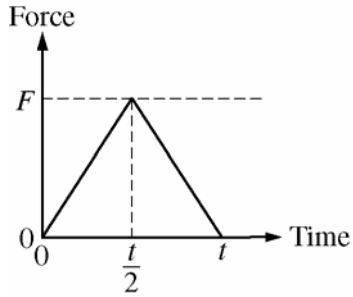

22. The graph above shows the force acting on an object as a function of time. The change in momentum of the object from time 0 to t is

- (A) $2Ft$
- (B) Ft
- (C) $\frac{1}{2}Ft$
- (D) $\frac{1}{4}Ft$
- (E) zero

Questions 23-24

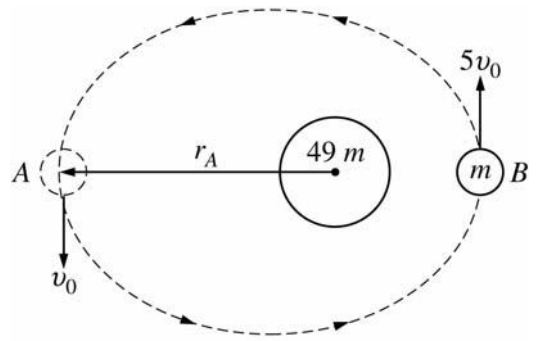

Note: Figure not drawn to scale.

A moon of mass m orbits a planet of mass $49m$ in an elliptical orbit as shown above. When the moon is at point A, its distance from the center of the planet is r_A and its speed is v_0 . When the moon is at point B, its speed is $5v_0$.

23. When the moon is at point A, the distance from the moon to the center of mass of the planet-moon system is most nearly

- (A) $\frac{1}{50} r_A$
- (B) $\frac{1}{7} r_A$
- (C) $\frac{1}{2} r_A$
- (D) $\frac{6}{7} r_A$
- (E) $\frac{49}{50} r_A$

24. When the moon is at point B, the distance from the moon to the center of the planet is most nearly

- (A) $\frac{1}{25} r_A$
- (B) $\frac{1}{5} r_A$
- (C) $\frac{1}{\sqrt{5}} r_A$
- (D) r_A
- (E) $\sqrt{5} r_A$

GO ON TO THE NEXT PAGE.

Questions 25-26

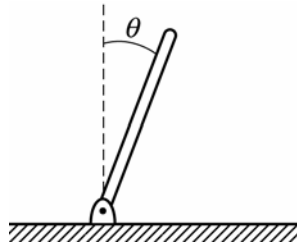

The bar shown above is pivoted about one end and is initially at rest in a vertical position. The bar is displaced slightly and as it falls it makes an angle θ with the vertical at any given time, as shown above.

25. Which of the following graphs best represents the bar's angular acceleration α as a function of angle θ ?

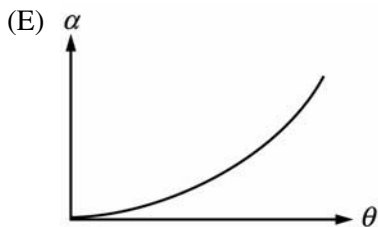
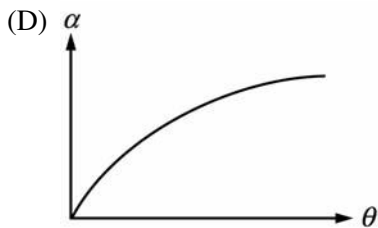
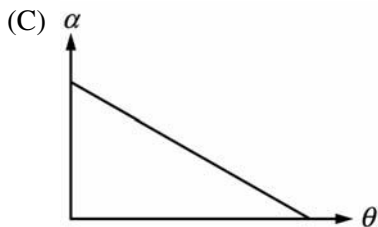
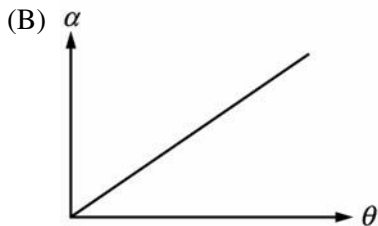
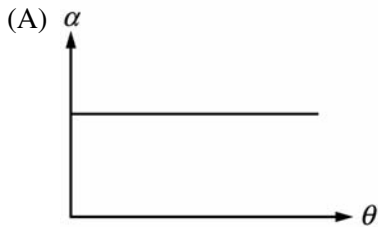

26. Which of the following graphs best represents the bar's angular velocity ω as a function of time?

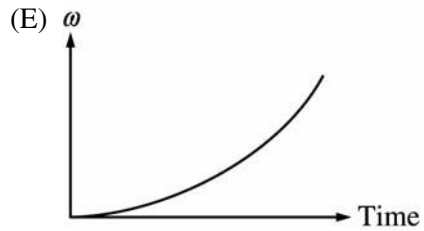
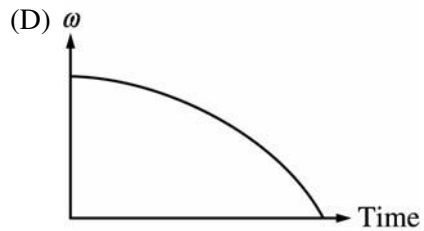
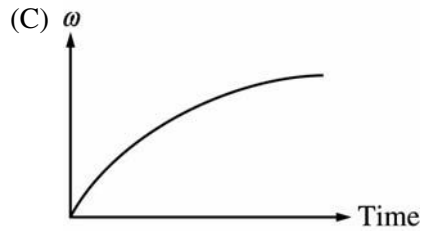
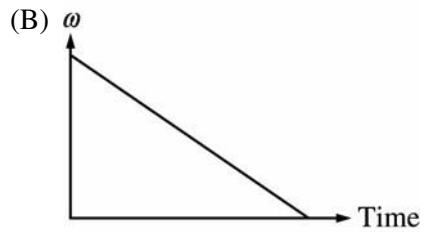
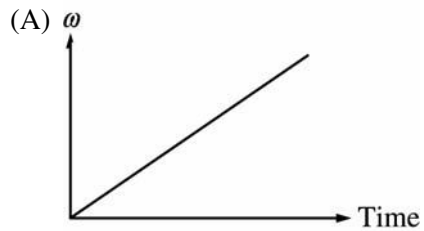

GO ON TO THE NEXT PAGE.

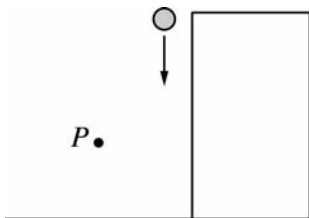

x (m)	F (N)
0	0
1	1
2	8
3	27
4	64

27. A stone falls from rest from the top of a building as shown above. Which of the following graphs best represents the stone's angular momentum L about the point P as a function of time?

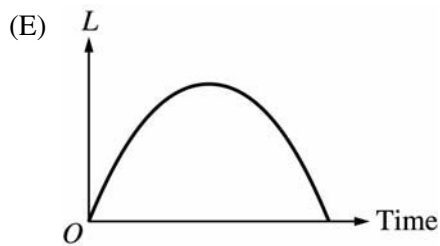
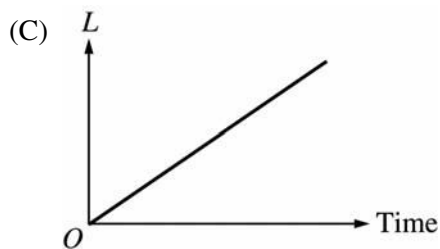
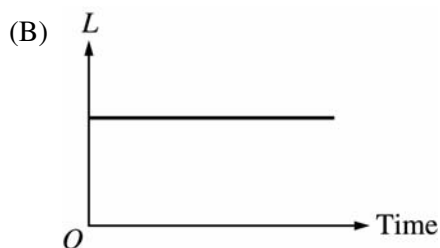
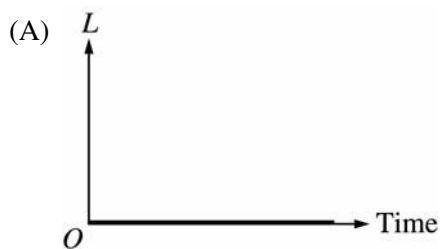

28. A specially designed spring is stretched from equilibrium to the distances x given in the table above, and the restoring force F is measured and recorded in each case. What is the potential energy of the spring when it is stretched 3 m from equilibrium?

(A) $\frac{9}{2}$ J

(B) 9 J

(C) $\frac{81}{4}$ J

(D) 27 J

(E) $\frac{81}{2}$ J

29. An object on the end of a spring with spring constant k moves in simple harmonic motion with amplitude A and frequency f . Which of the following is a possible expression for the kinetic energy of the object as a function of time t ?

(A) $kA^2 \sin^2(2\pi ft)$

(B) $\frac{1}{2}kA^2 \cos^2(2\pi ft)$

(C) $\frac{1}{2}kA \sin(2\pi ft)$

(D) $kA \cos(2\pi ft)$

(E) $kA(\sin 2\pi ft + \cos 2\pi ft)$

GO ON TO THE NEXT PAGE.

30. When a certain spring is stretched by an amount x , it produces a restoring force of $F(x) = -ax + bx^2$, where a and b are constants. How much work is done by an external force in stretching the spring by an amount D from its equilibrium length?

- (A) $-aD + bD^2$
- (B) $a - 2bD$
- (C) $\frac{1}{2}aD^2 - \frac{1}{3}bD^3$
- (D) $-aD^2 + bD^3$
- (E) $-2aD^2 + 3bD^3$

Questions 31-32 refer to the following.

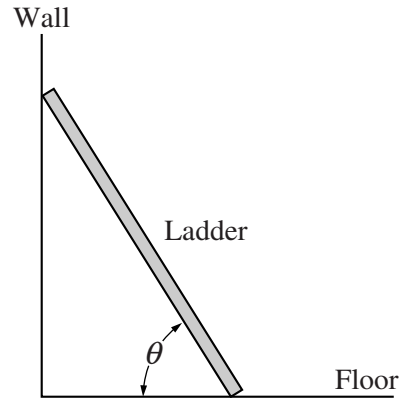

A uniform ladder of weight W leans without slipping against a wall making an angle θ with a floor as shown above. There is friction between the ladder and the floor, but the friction between the ladder and the wall is negligible.

31. The magnitude of the normal force exerted by the floor on the ladder is
- (A) W
 - (B) $W \sin \theta$
 - (C) $W \cos \theta$
 - (D) $\frac{W}{2} \sin \theta$
 - (E) $\frac{W}{2} \cos \theta$
32. The magnitude of the friction force exerted on the ladder by the floor is
- (A) $2W \tan \theta$
 - (B) W
 - (C) $W \cot \theta$
 - (D) $\frac{W}{2}$
 - (E) $\frac{W}{2} \cot \theta$

GO ON TO THE NEXT PAGE.

33. An ideal spring with spring constant k is cut in half. What is the spring constant of either one of the two half springs?

- (A) $\frac{k}{2}$
- (B) \sqrt{k}
- (C) k
- (D) k^2
- (E) $2k$

34. A rocket has landed on Planet X, which has half the radius of Earth. An astronaut onboard the rocket weighs twice as much on Planet X as on Earth. If the escape velocity for the rocket taking off from Earth is v_0 , then its escape velocity on Planet X is

- (A) $2v_0$
- (B) $\sqrt{2}v_0$
- (C) v_0
- (D) $v_0/2$
- (E) $v_0/4$

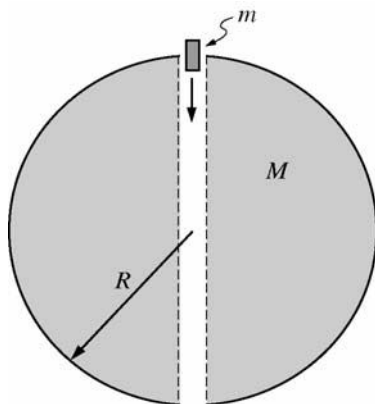

35. Suppose that a hole is drilled through the center of Earth to the other side along its axis. A small object of mass m is dropped from rest into the hole at the surface of Earth, as shown above. If Earth is assumed to be a solid sphere of mass M and radius R and friction is assumed to be negligible, correct expressions for the kinetic energy of the mass as it passes Earth's center include which of the following ?

- I. $\frac{1}{2}MgR$
- II. $\frac{1}{2}mgR$
- III. $\frac{GmM}{2R}$

- (A) I only
- (B) II only
- (C) III only
- (D) I and III only
- (E) II and III only

STOP

END OF MECHANICS SECTION I

**IF YOU FINISH BEFORE TIME IS CALLED,
YOU MAY CHECK YOUR WORK ON MECHANICS SECTION I ONLY.**

DO NOT TURN TO ANY OTHER TEST MATERIALS.

Section II

Free-Response Questions

TABLE OF INFORMATION FOR 2008 and 2009

CONSTANTS AND CONVERSION FACTORS	
Proton mass, $m_p = 1.67 \times 10^{-27}$ kg	Electron charge magnitude, $e = 1.60 \times 10^{-19}$ C
Neutron mass, $m_n = 1.67 \times 10^{-27}$ kg	1 electron volt, $1 \text{ eV} = 1.60 \times 10^{-19}$ J
Electron mass, $m_e = 9.11 \times 10^{-31}$ kg	Speed of light, $c = 3.00 \times 10^8$ m/s
Avogadro's number, $N_0 = 6.02 \times 10^{23}$ mol ⁻¹	Universal gravitational constant, $G = 6.67 \times 10^{-11}$ m ³ /kg·s ²
Universal gas constant, $R = 8.31$ J/(mol·K)	Acceleration due to gravity at Earth's surface, $g = 9.8$ m/s ²
Boltzmann's constant, $k_B = 1.38 \times 10^{-23}$ J/K	
1 unified atomic mass unit,	$1 \text{ u} = 1.66 \times 10^{-27}$ kg = $931 \text{ MeV}/c^2$
Planck's constant,	$h = 6.63 \times 10^{-34}$ J·s = 4.14×10^{-15} eV·s
	$hc = 1.99 \times 10^{-25}$ J·m = 1.24×10^3 eV·nm
Vacuum permittivity,	$\epsilon_0 = 8.85 \times 10^{-12}$ C ² /N·m ²
Coulomb's law constant, $k = 1/4\pi\epsilon_0 = 9.0 \times 10^9$ N·m ² /C ²	
Vacuum permeability,	$\mu_0 = 4\pi \times 10^{-7}$ (T·m)/A
Magnetic constant, $k' = \mu_0/4\pi = 10^{-7}$ (T·m)/A	
1 atmosphere pressure,	$1 \text{ atm} = 1.0 \times 10^5$ N/m ² = 1.0×10^5 Pa

UNIT SYMBOLS	meter, m	mole, mol	watt, W	farad, F
	kilogram, kg	hertz, Hz	coulomb, C	tesla, T
	second, s	newton, N	volt, V	degree Celsius, °C
	ampere, A	pascal, Pa	ohm, Ω	electron-volt, eV
	kelvin, K	joule, J	henry, H	

PREFIXES		
Factor	Prefix	Symbol
10 ⁹	giga	G
10 ⁶	mega	M
10 ³	kilo	k
10 ⁻²	centi	c
10 ⁻³	milli	m
10 ⁻⁶	micro	μ
10 ⁻⁹	nano	n
10 ⁻¹²	pico	p

VALUES OF TRIGONOMETRIC FUNCTIONS FOR COMMON ANGLES							
θ	0°	30°	37°	45°	53°	60°	90°
$\sin \theta$	0	1/2	3/5	$\sqrt{2}/2$	4/5	$\sqrt{3}/2$	1
$\cos \theta$	1	$\sqrt{3}/2$	4/5	$\sqrt{2}/2$	3/5	1/2	0
$\tan \theta$	0	$\sqrt{3}/3$	3/4	1	4/3	$\sqrt{3}$	∞

The following conventions are used in this exam.

- I. Unless otherwise stated, the frame of reference of any problem is assumed to be inertial.
- II. The direction of any electric current is the direction of flow of positive charge (conventional current).
- III. For any isolated electric charge, the electric potential is defined as zero at an infinite distance from the charge.

ADVANCED PLACEMENT PHYSICS C EQUATIONS FOR 2008 and 2009

MECHANICS

$$v = v_0 + at$$

$$x = x_0 + v_0t + \frac{1}{2}at^2$$

$$v^2 = v_0^2 + 2a(x - x_0)$$

$$\Sigma \mathbf{F} = \mathbf{F}_{net} = m\mathbf{a}$$

$$\mathbf{F} = \frac{d\mathbf{p}}{dt}$$

$$\mathbf{J} = \int \mathbf{F} dt = \Delta \mathbf{p}$$

$$\mathbf{p} = m\mathbf{v}$$

$$F_{fric} \leq \mu N$$

$$W = \int \mathbf{F} \cdot d\mathbf{r}$$

$$K = \frac{1}{2}mv^2$$

$$P = \frac{dW}{dt}$$

$$P = \mathbf{F} \cdot \mathbf{v}$$

$$\Delta U_g = mgh$$

$$a_c = \frac{v^2}{r} = \omega^2 r$$

$$\boldsymbol{\tau} = \mathbf{r} \times \mathbf{F}$$

$$\Sigma \boldsymbol{\tau} = \boldsymbol{\tau}_{net} = I\boldsymbol{\alpha}$$

$$I = \int r^2 dm = \Sigma mr^2$$

$$\mathbf{r}_{cm} = \Sigma m\mathbf{r} / \Sigma m$$

$$v = r\omega$$

$$\mathbf{L} = \mathbf{r} \times \mathbf{p} = I\boldsymbol{\omega}$$

$$K = \frac{1}{2}I\omega^2$$

$$\omega = \omega_0 + \alpha t$$

$$\theta = \theta_0 + \omega_0 t + \frac{1}{2}\alpha t^2$$

a = acceleration
 F = force
 f = frequency
 h = height
 I = rotational inertia
 J = impulse
 K = kinetic energy
 k = spring constant
 ℓ = length
 L = angular momentum
 m = mass
 N = normal force
 P = power
 p = momentum
 r = radius or distance
 \mathbf{r} = position vector
 T = period
 t = time
 U = potential energy
 v = velocity or speed
 W = work done on a system
 x = position
 μ = coefficient of friction
 θ = angle
 τ = torque
 ω = angular speed
 α = angular acceleration

$$\mathbf{F}_s = -k\mathbf{x}$$

$$U_s = \frac{1}{2}kx^2$$

$$T = \frac{2\pi}{\omega} = \frac{1}{f}$$

$$T_s = 2\pi\sqrt{\frac{m}{k}}$$

$$T_p = 2\pi\sqrt{\frac{\ell}{g}}$$

$$\mathbf{F}_G = -\frac{Gm_1m_2}{r^2}\hat{\mathbf{r}}$$

$$U_G = -\frac{Gm_1m_2}{r}$$

ELECTRICITY AND MAGNETISM

$$F = \frac{1}{4\pi\epsilon_0} \frac{q_1q_2}{r^2}$$

$$\mathbf{E} = \frac{\mathbf{F}}{q}$$

$$\oint \mathbf{E} \cdot d\mathbf{A} = \frac{Q}{\epsilon_0}$$

$$E = -\frac{dV}{dr}$$

$$V = \frac{1}{4\pi\epsilon_0} \sum_i \frac{q_i}{r_i}$$

$$U_E = qV = \frac{1}{4\pi\epsilon_0} \frac{q_1q_2}{r}$$

$$C = \frac{Q}{V}$$

$$C = \frac{\kappa\epsilon_0 A}{d}$$

$$C_p = \sum_i C_i$$

$$\frac{1}{C_s} = \sum_i \frac{1}{C_i}$$

$$I = \frac{dQ}{dt}$$

$$U_c = \frac{1}{2}QV = \frac{1}{2}CV^2$$

$$R = \frac{\rho\ell}{A}$$

$$\mathbf{E} = \rho\mathbf{J}$$

$$I = Nev_dA$$

$$V = IR$$

$$R_s = \sum_i R_i$$

$$\frac{1}{R_p} = \sum_i \frac{1}{R_i}$$

$$P = IV$$

$$\mathbf{F}_M = q\mathbf{v} \times \mathbf{B}$$

A = area
 B = magnetic field
 C = capacitance
 d = distance
 E = electric field
 \mathcal{E} = emf
 F = force
 I = current
 J = current density
 L = inductance
 ℓ = length
 n = number of loops of wire per unit length
 N = number of charge carriers per unit volume
 P = power
 Q = charge
 q = point charge
 R = resistance
 r = distance
 t = time
 U = potential or stored energy
 V = electric potential
 v = velocity or speed
 ρ = resistivity
 ϕ_m = magnetic flux
 κ = dielectric constant

$$\oint \mathbf{B} \cdot d\boldsymbol{\ell} = \mu_0 I$$

$$d\mathbf{B} = \frac{\mu_0}{4\pi} \frac{I d\boldsymbol{\ell} \times \mathbf{r}}{r^3}$$

$$\mathbf{F} = \int I d\boldsymbol{\ell} \times \mathbf{B}$$

$$B_s = \mu_0 nI$$

$$\phi_m = \int \mathbf{B} \cdot d\mathbf{A}$$

$$\mathcal{E} = -\frac{d\phi_m}{dt}$$

$$\mathcal{E} = -L \frac{dI}{dt}$$

$$U_L = \frac{1}{2}LI^2$$

GEOMETRY AND TRIGONOMETRY

Rectangle

$$A = bh$$

Triangle

$$A = \frac{1}{2}bh$$

Circle

$$A = \pi r^2$$

$$C = 2\pi r$$

Parallelepiped

$$V = \ell wh$$

Cylinder

$$V = \pi r^2 \ell$$

$$S = 2\pi r \ell + 2\pi r^2$$

Sphere

$$V = \frac{4}{3}\pi r^3$$

$$S = 4\pi r^2$$

Right Triangle

$$a^2 + b^2 = c^2$$

$$\sin \theta = \frac{a}{c}$$

$$\cos \theta = \frac{b}{c}$$

$$\tan \theta = \frac{a}{b}$$

A = area
 C = circumference
 V = volume
 S = surface area
 b = base
 h = height
 ℓ = length
 w = width
 r = radius

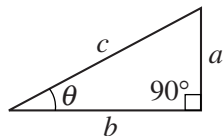

CALCULUS

$$\frac{df}{dx} = \frac{df}{du} \frac{du}{dx}$$

$$\frac{d}{dx}(x^n) = nx^{n-1}$$

$$\frac{d}{dx}(e^x) = e^x$$

$$\frac{d}{dx}(\ln x) = \frac{1}{x}$$

$$\frac{d}{dx}(\sin x) = \cos x$$

$$\frac{d}{dx}(\cos x) = -\sin x$$

$$\int x^n dx = \frac{1}{n+1} x^{n+1}, n \neq -1$$

$$\int e^x dx = e^x$$

$$\int \frac{dx}{x} = \ln|x|$$

$$\int \cos x dx = \sin x$$

$$\int \sin x dx = -\cos x$$

PHYSICS C: MECHANICS

SECTION II

Time—45 minutes

3 Questions

Directions: Answer all three questions. The suggested time is about 15 minutes for answering each of the questions, which are worth 15 points each. The parts within a question may not have equal weight. All final numerical answers should include appropriate units. Credit depends on the quality of your solutions and explanations, so you should show your work. Credit also depends on demonstrating that you know which physical principles would be appropriate to apply in a particular situation. Therefore, you should clearly indicate which part of a question your work is for.

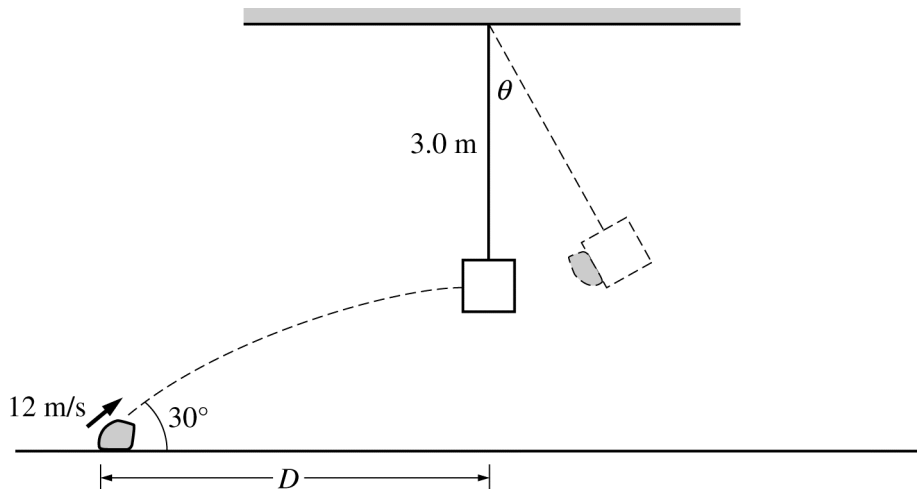

Mech. 1.

A chunk of clay of mass 0.20 kg is thrown from the ground with an initial speed of 12 m/s at an angle of 30° with the horizontal, as shown above. At the top of its trajectory, the clay strikes a small block of mass 2.3 kg suspended from a 3.0 m long string. The clay sticks to the block, which then swings freely. Neglect air resistance.

- (a) Calculate the horizontal distance D between the launching point of the clay and a point on the floor directly below the initial position of the block.
- (b) Calculate the speed of the block-clay system immediately after the collision with the clay.
- (c) Calculate the angle θ through which the block-clay system will rise before coming momentarily to rest.
- (d) Calculate the time between when the block is struck and when it first returns to its original position.
- (e) The procedure is repeated with a chunk of clay of greater mass. Indicate whether the new angle θ will be greater than, less than, or the same as that determined in (c).

___ Greater ___ Less ___ The same

Justify your answer.

GO ON TO THE NEXT PAGE.

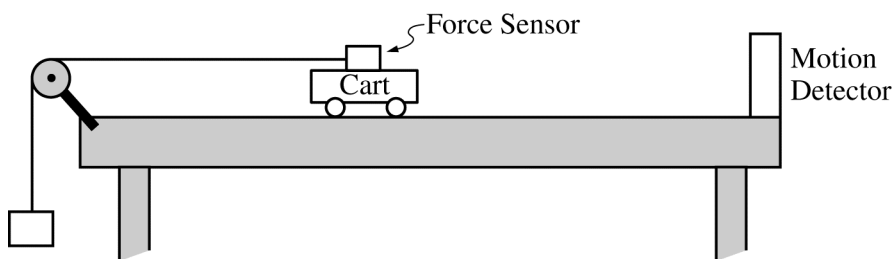

Mech. 2.

In the lab apparatus above, a force sensor attached to a cart is connected by a string to a block. The string passes over a pulley. The block is allowed to fall, accelerating the cart. A computer attached to the force sensor and a motion detector displays the position, the speed, and the force applied to the cart at five different locations, as given in the table below. The square of the speed is also provided.

Position (m)	Speed (m/s)	Force (N)	Speed ² (m ² /s ²)
0.00	0.55	0.84	0.30
0.10	0.66	0.85	0.44
0.20	0.85	0.84	0.73
0.30	0.94	0.83	0.88
0.40	1.08	0.85	1.17

- (a) i. Determine the average force exerted by the string.
 ii. Estimate the work done by the average force on the cart during the time that data was taken.
- (b) i. On the axes below, graph the square of the speed versus position.

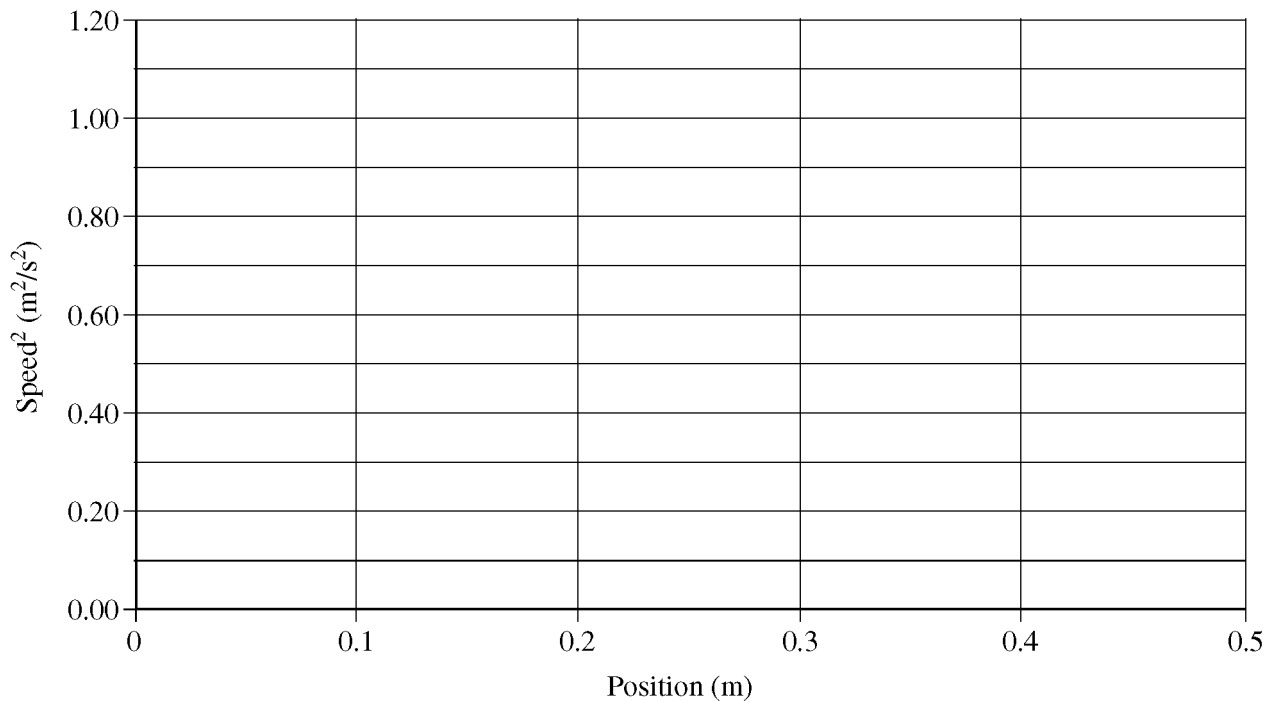

- ii. Draw a best-fit line through the points.

GO ON TO THE NEXT PAGE.

(c) Calculate the acceleration of the cart from the best-fit line.

The mass of the cart is 0.65 kg.

(d) Use a method different from that used in (a) ii. to calculate the work done on the cart from the data given.

(e) Indicate whether the values you obtained in (a) and (d) are in agreement. If they are, explain why they should be. If they are not, indicate a possible cause of the discrepancy.

GO ON TO THE NEXT PAGE.

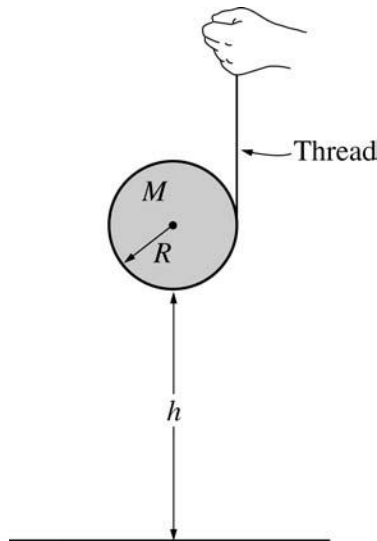

Mech. 3.

A student holds one end of a thread, which is wrapped around a cylindrical spool, as shown above. The student then drops the spool from a height h above the floor, and the thread unwinds as it falls. The spool has a mass M and a radius R , and the thread has negligible mass. The spool can be approximated as a solid cylinder of moment of inertia $I = \frac{1}{2}MR^2$. Express your answers in terms of M , R , h , and fundamental constants.

- (a) Calculate the linear acceleration of the spool as it falls.
- (b) Calculate the angular velocity of the spool just before it strikes the floor.

At time $t = 0$, the spinning spool lands on the floor without bouncing and comes free from the thread. It continues to spin, but slips on the floor's surface while doing so. Assume a constant coefficient of sliding friction μ .

- (c) Calculate the angular velocity of the spool as a function of time t .
- (d) Calculate the horizontal speed of the spool as a function of time, assuming the horizontal speed is zero at time $t = 0$.
- (e) At what time does slipping between the spool and floor cease?

STOP

END OF EXAM

Name: _____

AP[®] Physics C: Mechanics
Student Answer Sheet for Multiple-Choice Section

No.	Answer
1	
2	
3	
4	
5	
6	
7	
8	
9	
10	
11	
12	
13	
14	
15	
16	
17	
18	
19	
20	
21	
22	
23	
24	
25	
26	
27	
28	
29	
30	

No.	Answer
31	
32	
33	
34	
35	

AP[®] Physics C: Mechanics
Multiple-Choice Answer Key

No.	Correct Answer
1	D
2	D
3	B
4	E
5	D
6	A
7	A
8	D
9	D
10	A
11	A
12	D
13	B
14	D
15	D
16	E
17	E
18	B
19	D
20	E
21	C
22	C
23	E
24	B
25	D
26	E
27	C
28	C
29	B
30	C

No.	Correct Answer
31	A
32	E
33	E
34	C
35	E

AP[®] Physics C: Mechanics

Free-Response Scoring Guidelines

General Notes about AP Physics Practice Exam Scoring Guidelines

1. The solutions contain a common method of solving the free-response questions and the allocation of points for the solutions. Some also contain a common alternate solution. They are typical of draft guidelines developed before student solutions are available. Teachers should feel free to make modifications based on their students' responses.
2. The scoring guidelines typically show numerical results using the value $g = 9.8 \text{ m/s}^2$, but use of 10 m/s^2 is of course also acceptable. Solutions usually show numerical answers using both values when they are significantly different.

The following rules apply to the official scoring of AP Physics Exams.

3. All correct methods of solution receive appropriate credit for correct work.
4. Generally, double penalty for errors is avoided. For example, if an incorrect answer to part (a) is correctly substituted into an otherwise correct solution to part (b), full credit will usually be awarded. One exception to this may be cases when the numerical answer to a later part should be easily recognized as wrong, e.g., a speed faster than the speed of light in vacuum.
5. Implicit statements of concepts normally receive credit. For example, if use of the equation expressing a particular concept is worth 1 point, and a student's solution contains the application of that equation to the problem but the student does not write the basic equation, the point is still awarded. However, when students are asked to derive an expression, it is normally expected that they will begin by writing one or more fundamental equations, such as those given on the AP Physics Exam equation sheet. For a description of the use of such terms as "derive" and "calculate" on the exams, and what is expected for each, see "The Free-Response Sections—Student Presentation" in the *AP Physics Course Description*.
6. Strict rules regarding significant digits are usually not applied to numerical answers. However, in some cases answers containing too many digits may be penalized. In general, two to four significant digits are acceptable. Numerical answers that differ from the published answer due to differences in rounding throughout the question typically receive full credit. Exceptions to these guidelines usually occur when rounding makes a difference in obtaining a reasonable answer. For example, suppose a solution requires subtracting two numbers that should have five significant figures and that differ starting with the fourth digit (e.g., 20.295 and 20.278). Rounding to three digits will lose the accuracy required to determine the difference in the numbers, and some credit may be lost.

AP[®] Physics C: Mechanics
Free-Response Scoring Guidelines

Question 1

15 points total

**Distribution
of points**

(a) 5 points

For using a correct kinematic equation to determine the time of flight

1 point

$$v_y = v_{y0} - gt$$

For correctly using the vertical component of the initial velocity

1 point

$$v_{y0} = v_0 \sin 30^\circ$$

$$0 = v_0 \sin 30^\circ - gt$$

For a correct expression for the time

1 point

$$t = \frac{v_0 \sin 30^\circ}{g}$$

$$t = \frac{(12.0 \text{ m/s}) \sin 30^\circ}{9.8 \text{ m/s}^2} = 0.61 \text{ s}$$

For a correct kinematic equation including correct use of the horizontal component of the initial velocity

1 point

$$D = v_x t$$

$$v_x = v_0 \cos 30^\circ = 10.4 \text{ m/s}$$

$$D = (10.4 \text{ m/s})(0.61 \text{ s})$$

For the correct answer

1 point

$$D = 6.4 \text{ m} \quad (\text{or } 6.2 \text{ m using } g = 10 \text{ m/s}^2)$$

(b) 3 points

For applying conservation of momentum

1 point

For correctly using the sum of the clay and block masses after the collision

1 point

$$mv_x = (m + M)v_f$$

$$v_f = \frac{m}{m + M} v_x$$

$$v_f = \frac{0.20 \text{ kg}}{0.20 \text{ kg} + 2.3 \text{ kg}} (10.4 \text{ m/s})$$

For the correct answer

1 point

$$v_f = 0.83 \text{ m/s}$$

AP[®] Physics C: Mechanics
Free-Response Scoring Guidelines

Question 1 (continued)

		Distribution of points
(c)	3 points	
	For applying conservation of energy	1 point
	$\frac{1}{2}(m + M)v_f^2 = (m + M)g\Delta h$	
	Solving for Δh	
	$\Delta h = \frac{v_f^2}{2g} = \frac{(0.83 \text{ m/s})^2}{2(9.8 \text{ m/s}^2)} = 0.035 \text{ m}$	
	For applying the correct trigonometry relating Δh and the length of the string ℓ	1 point
	$\Delta h = \ell - \ell \cos \theta$	
	$\theta = \cos^{-1}\left(\frac{\ell - \Delta h}{\ell}\right) = \cos^{-1}\left(\frac{3.0 - 0.035}{3.0}\right) = 8.8^\circ$	
	For the correct answer	1 point
	$\theta = 8.8^\circ \text{ (or } 8.7^\circ \text{ using } g = 10 \text{ m/s}^2\text{)}$	
(d)	2 points	
	For correctly calculating the period	1 point
	$T = 2\pi \sqrt{\frac{\ell}{g}}$	
	$T = 2\pi \sqrt{\frac{3.0 \text{ m}}{9.8 \text{ m/s}^2}} = 3.5 \text{ s}$	
	For an indication that the requested time is one-half the period	1 point
	$t = \frac{1}{2}T = 1.7 \text{ s}$	
(e)	2 points	
	For correctly indicating that the new angle is greater	1 point
	For a correct justification	1 point
	For example: Substituting the expression for v_f from part (b) into the first expression for	
	$\Delta h \text{ from part (c): } \Delta h = \frac{1}{2g}\left(\frac{m}{m + M}\right)^2 v_x^2$	
	Increasing the mass m increases the height achieved by the pendulum; hence, the resulting angle is greater than that achieved with the original mass.	

AP[®] Physics C: Mechanics
Free-Response Scoring Guidelines

Question 2

15 points total

Distribution
of points

(a)

(i) 1 point

For a correct determination of the average force

$$F_{avg} = \frac{(0.84 + 0.85 + 0.84 + 0.83 + 0.85) \text{ N}}{5} = 0.84 \text{ N}$$

1 point

(ii) 1 point

$$W = F_{avg} x$$

$$W = (0.84 \text{ N})(0.40 \text{ m})$$

For the correct answer

$$W = 0.34 \text{ J}$$

1 point

(b)

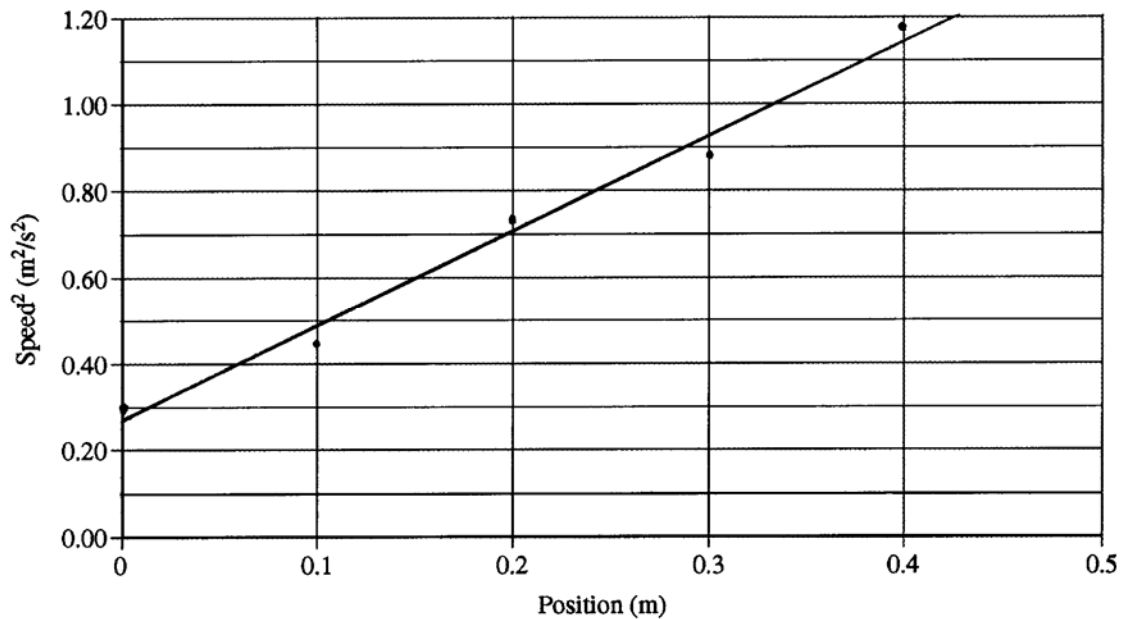

(i) 2 points

For correctly plotting four of the five given points

2 points

(ii) 1 point

For correctly drawing a straight line that has at least two data points above the line and two points below the line

1 point

AP[®] Physics C: Mechanics
Free-Response Scoring Guidelines

Question 2 (continued)

		Distribution of points
(c)	4 points	
	For applying the correct kinematic equation to determine the acceleration $v^2 = v_0^2 + 2ax$	1 point
	For correctly equating the slope of the graph to twice the acceleration Slope = $2a$	1 point
	For correct determination of the slope using points clearly on the best-fit line (Using data points not on the line does not receive credit.)	1 point
	For example, using points on the graph shown: $\text{Slope} = \frac{(0.93 - 0.49)\text{m}^2/\text{s}^2}{(0.3 - 0.1)\text{m}} = 2.20 \text{ m/s}^2$	
	For a numerical answer in the range 0.83 to 1.3 m/s^2 $a = 1.10 \text{ m/s}^2$	1 point
(d)	3 points	
	For correct identification of a valid alternative method For example, conservation of energy:	2 points
	$W = \frac{1}{2}m(v_f^2 - v_i^2)$	
	$W = \frac{1}{2}(0.65 \text{ kg})((1.08 \text{ m/s})^2 - (0.55 \text{ m/s})^2)$	
	For the correct answer $W = 0.28 \text{ J}$	1 point
(e)	2 points	
	For a reasonable answer based on the two values of work obtained	1 point
	For a correct and substantive explanation	1 point
	For example: The work calculated in (d) is less than the work calculated in (a). Part (a) includes only the positive work performed on the cart by the string. There could be energy dissipated due to friction, which is included when you calculate the actual change in kinetic energy in part (d).	
Units	1 point	
	For correct units in all final numerical answers	1 point

AP[®] Physics C: Mechanics
Free-Response Scoring Guidelines

Question 3

15 points total

**Distribution
of points**

(a) 4 points

For correctly applying Newton's second law

$$Ma = Mg - T$$

1 point

For correctly applying a torque equation relating T and α

$$\tau = TR = I\alpha$$

1 point

For correctly incorporating the relationship between α and a

$$TR = I\alpha = I\frac{a}{R}$$

1 point

$$T = I\frac{a}{R^2}$$

Substituting into the equation for Newton's second law

$$Ma = Mg - \frac{Ia}{R^2}$$

$$Mg = a\left(M + \frac{I}{R^2}\right)$$

Substituting the given expression for I

$$Mg = a\left(M + \frac{1}{R^2}\left(\frac{1}{2}MR^2\right)\right)$$

$$Mg = a\left(M + \frac{M}{2}\right) = \frac{3}{2}Ma$$

For the correct answer

$$a = \frac{2}{3}g$$

1 point

(b) 3 points

For applying conservation of energy

1 point

For correctly including all three terms (gravitational potential, linear kinetic, rotational kinetic)

1 point

$$Mgh = \frac{1}{2}Mv^2 + \frac{1}{2}I\omega^2$$

Substituting $v = r\omega$ and the given expression for I

$$Mgh = \frac{1}{2}MR^2\omega^2 + \frac{1}{2}\left(\frac{1}{2}MR^2\right)\omega^2$$

$$Mgh = \frac{3}{4}MR^2\omega^2$$

For the correct answer

1 point

$$\omega = \sqrt{\frac{4gh}{3R^2}}$$

AP[®] Physics C: Mechanics
Free-Response Scoring Guidelines

Question 3 (continued)

		Distribution of points
	<i>Alternate solution</i>	<i>Alternate points</i>
	For correctly substituting the acceleration from part (a) into the kinematic equation	1 point
	$v^2 = v_0^2 + 2a(y - y_0)$	
	$v^2 = 2\left(\frac{2}{3}g\right)h = \frac{4gh}{3}$	
	For substituting v into the expression $\omega = v/R$	1 point
	$\omega = \frac{v}{R} = \frac{\sqrt{4gh/3}}{R}$	
	For the correct answer	1 point
	$\omega = \sqrt{\frac{4gh}{3R^2}}$	
	<i>Note: Another alternate solution, obtained by combining the time determined by kinematics with the expression relating angular impulse and change in angular momentum, would also be acceptable if correctly implemented.</i>	
(c)	4 points	
	For applying the torque equation	1 point
	For a correct expression for the torque due to friction	1 point
	$\tau = I\alpha = -\mu MgR$	
	$\frac{1}{2}MR^2\alpha = -\mu MgR$	
	$\alpha = -\frac{2\mu g}{R}$	
	For applying the appropriate rotational kinematic equation	1 point
	$\omega = \omega_0 + \alpha t$	
	For using the result of part (b) as the initial angular velocity	1 point
	$\omega = \sqrt{\frac{4gh}{3R^2}} - \frac{2\mu g}{R}t$	
(d)	2 points	
	For correct use of Newton's second law and a kinematic equation	1 point
	$Ma = \mu Mg$	
	$a = \mu g$	
	$v = at$	
	For the correct answer	1 point
	$v = \mu gt$	

AP[®] Physics C: Mechanics
Free-Response Scoring Guidelines

Question 3 (continued)

Distribution
of points

(e) 2 points

For correctly stating the condition for cessation of slipping

$$v = R\omega$$

1 point

For correctly substituting results from parts (c) and (d)

1 point

$$\mu gt = R \left[\sqrt{\frac{4gh}{3R^2}} - \frac{2\mu g}{R} t \right]$$

$$\mu gt = 2\sqrt{\frac{gh}{3}} - 2\mu gt$$

$$t = \frac{2}{3\mu} \sqrt{\frac{h}{3g}} = \sqrt{\frac{4h}{27\mu^2 g}}$$