

PHYSICS C

SECTION I, MECHANICS

Time—45 minutes

35 Questions

Directions: Each of the questions or incomplete statements below is followed by five suggested answers or completions. Select the one that is best in each case and then fill in the corresponding oval on the answer sheet.

Note: To simplify calculations, you may use $g = 10 \text{ m/s}^2$ in all problems.

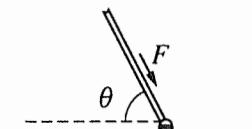

1. A force F is exerted by a broom handle on the head of the broom, which has a mass m . The handle is at an angle θ to the horizontal, as shown above. The work done by the force on the head of the broom as it moves a distance d across a horizontal floor is

- (A) $Fd \sin \theta$
 (B) $Fd \cos \theta$
 (C) $Fm \cos \theta$
 (D) $Fm \tan \theta$
 (E) $Fmd \sin \theta$

2. The velocity of a projectile at launch has a horizontal component v_h and a vertical component v_v . Air resistance is negligible. When the projectile is at the highest point of its trajectory, which of the following show the vertical and horizontal components of its velocity and the vertical component of its acceleration?

	Vertical Velocity	Horizontal Velocity	Vertical Acceleration
(A)	v_v	v_h	0
(B)	v_v	0	0
(C)	0	v_h	0
(D)	0	0	g
(E)	0	v_h	g

GO ON TO THE NEXT PAGE

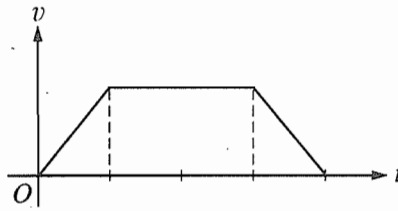

3. The graph above shows the velocity v as a function of time t for an object moving in a straight line. Which of the following graphs shows the corresponding displacement x as a function of time t for the same time interval?

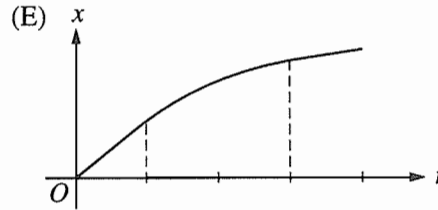
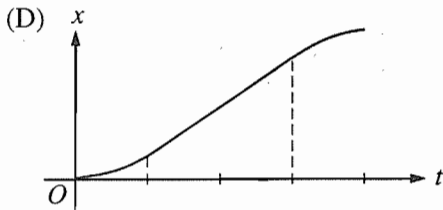
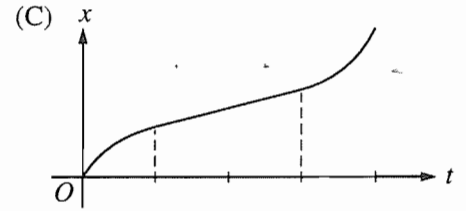
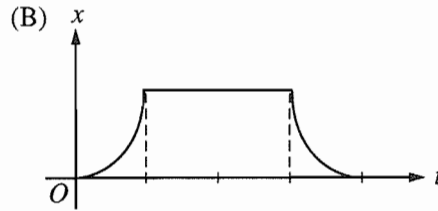
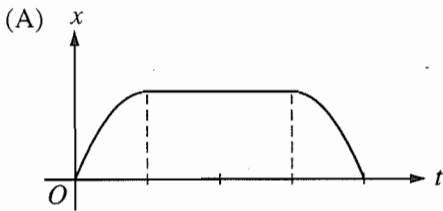

GO ON TO THE NEXT PAGE 

4. The position of a toy locomotive moving on a straight track along the x -axis is given by the equation $x = t^3 - 6t^2 + 9t$, where x is in meters and t is in seconds. The net force on the locomotive is equal to zero when t is equal to
- (A) zero
 - (B) 2 s
 - (C) 3 s
 - (D) 4 s
 - (E) 5 s

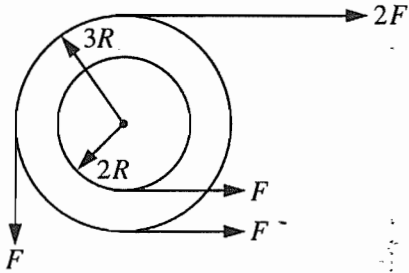

5. A system of two wheels fixed to each other is free to rotate about a frictionless axis through the common center of the wheels and perpendicular to the page. Four forces are exerted tangentially to the rims of the wheels, as shown above. The magnitude of the net torque on the system about the axis is
- (A) zero
 - (B) FR
 - (C) $2FR$
 - (D) $5FR$
 - (E) $14FR$

6. A wheel of mass M and radius R rolls on a level surface without slipping. If the angular velocity of the wheel is ω , what is its linear momentum?
- (A) $M\omega R$
 - (B) $M\omega^2 R$
 - (C) $M\omega R^2$
 - (D) $\frac{M\omega^2 R^2}{2}$
 - (E) Zero

GO ON TO THE NEXT PAGE

Questions 7-8 refer to a ball that is tossed straight up from the surface of a small, spherical asteroid with no atmosphere. The ball rises to a height equal to the asteroid's radius and then falls straight down toward the surface of the asteroid.

7. What forces, if any, act on the ball while it is on the way up?
- (A) Only a decreasing gravitational force that acts downward
 - (B) Only an increasing gravitational force that acts downward
 - (C) Only a constant gravitational force that acts downward
 - (D) Both a constant gravitational force that acts downward and a decreasing force that acts upward
 - (E) No forces act on the ball.
8. The acceleration of the ball at the top of its path is
- (A) at its maximum value for the ball's flight
 - (B) equal to the acceleration at the surface of the asteroid
 - (C) equal to one-half the acceleration at the surface of the asteroid
 - (D) equal to one-fourth the acceleration at the surface of the asteroid
 - (E) zero

-
9. The equation of motion of a simple harmonic oscillator is $\frac{d^2x}{dt^2} = -9x$, where x is displacement and t is time. The period of oscillation is

- (A) 6π
- (B) $\frac{9}{2\pi}$
- (C) $\frac{3}{2\pi}$
- (D) $\frac{2\pi}{3}$
- (E) $\frac{2\pi}{9}$

10. A pendulum with a period of 1 s on Earth, where the acceleration due to gravity is g , is taken to another planet, where its period is 2 s. The acceleration due to gravity on the other planet is most nearly

- (A) $g/4$
- (B) $g/2$
- (C) g
- (D) $2g$
- (E) $4g$

11. A satellite of mass M moves in a circular orbit of radius R with constant speed v . True statements about this satellite include which of the following?

- I. Its angular speed is v/R .
- II. Its tangential acceleration is zero.
- III. The magnitude of its centripetal acceleration is constant.

- (A) I only
- (B) II only
- (C) I and III only
- (D) II and III only
- (E) I, II, and III

GO ON TO THE NEXT PAGE 

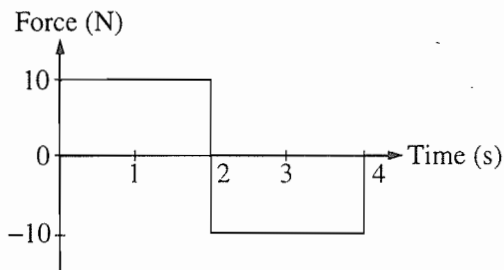

12. The graph above shows the force on an object of mass M as a function of time. For the time interval 0 to 4 s, the total change in the momentum of the object is
- (A) 40 kg·m/s
 (B) 20 kg·m/s
 (C) 0 kg·m/s
 (D) -20 kg·m/s
 (E) indeterminate unless the mass M of the object is known

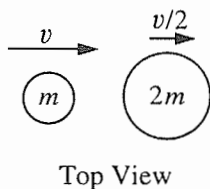

13. As shown in the top view above, a disc of mass m is moving horizontally to the right with speed v on a table with negligible friction when it collides with a second disc of mass $2m$. The second disc is moving horizontally to the right with speed $\frac{v}{2}$ at the moment of impact. The two discs stick together upon impact. The speed of the composite body immediately after the collision is
- (A) $\frac{v}{3}$
 (B) $\frac{v}{2}$
 (C) $\frac{2v}{3}$
 (D) $\frac{3v}{2}$
 (E) $2v$

Questions 14-15

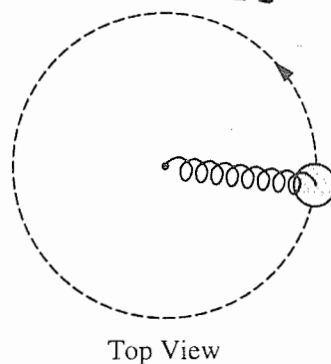

A spring has a force constant of 100 N/m and an unstretched length of 0.07 m. One end is attached to a post that is free to rotate in the center of a smooth table, as shown in the top view above. The other end is attached to a 1 kg disc moving in uniform circular motion on the table, which stretches the spring by 0.03 m. Friction is negligible.

14. What is the centripetal force on the disc?
- (A) 0.3 N
 (B) 3 N
 (C) 10 N
 (D) 300 N
 (E) 1,000 N
15. What is the work done on the disc by the spring during one full circle?
- (A) 0 J
 (B) 94 J
 (C) 186 J
 (D) 314 J
 (E) 628 J

GO ON TO THE NEXT PAGE

Questions 16-17 refer to the following graph, which represents a hypothetical potential energy curve for a particle of mass m .

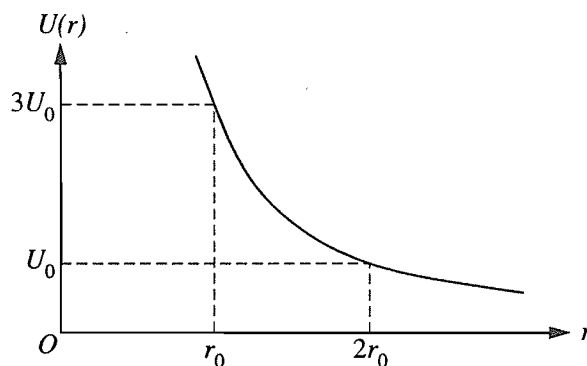

16. If the particle is released from rest at position r_0 , its speed at position $2r_0$ is most nearly

- (A) $\sqrt{\frac{8U_0}{m}}$
- (B) $\sqrt{\frac{6U_0}{m}}$
- (C) $\sqrt{\frac{4U_0}{m}}$
- (D) $\sqrt{\frac{2U_0}{m}}$
- (E) $\sqrt{\frac{U_0}{m}}$

17. If the potential energy function is given by

$$U(r) = br^{-3/2} + c, \text{ where } b \text{ and } c \text{ are constants,}$$

which of the following is an expression for the force on the particle?

- (A) $\frac{3b}{2} r^{-5/2}$
- (B) $\frac{3b}{2} r^{-1/2}$
- (C) $\frac{3}{2} r^{-1/2}$
- (D) $2br^{-1/2} + cr$
- (E) $\frac{2b}{5} r^{-5/2} + cr$

GO ON TO THE NEXT PAGE

18. A frictionless pendulum of length 3 m swings with an amplitude of 10° . At its maximum displacement, the potential energy of the pendulum is 10 J. What is the kinetic energy of the pendulum when its potential energy is 5 J?

(A) 3.3 J
 (B) 5 J
 (C) 6.7 J
 (D) 10 J
 (E) 15 J

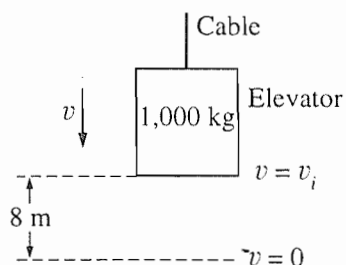

19. A descending elevator of mass 1,000 kg is uniformly decelerated to rest over a distance of 8 m by a cable in which the tension is 11,000 N. The speed v_i of the elevator at the beginning of the 8 m descent is most nearly

(A) 4 m/s
 (B) 10 m/s
 (C) 13 m/s
 (D) 16 m/s
 (E) 21 m/s

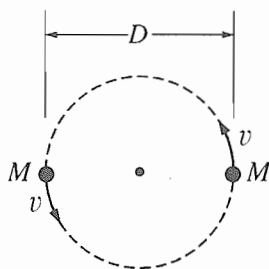

20. Two identical stars, a fixed distance D apart, revolve in a circle about their mutual center of mass, as shown above. Each star has mass M and speed v . G is the universal gravitational constant. Which of the following is a correct relationship among these quantities?

(A) $v^2 = GM/D$
 (B) $v^2 = GM/2D$
 (C) $v^2 = GM/D^2$
 (D) $v^2 = MGD$
 (E) $v^2 = 2GM^2/D$

Questions 21-22

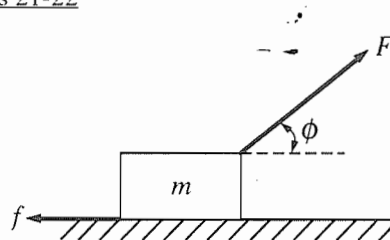

A block of mass m is accelerated across a rough surface by a force of magnitude F that is exerted at an angle ϕ with the horizontal, as shown above. The frictional force on the block exerted by the surface has magnitude f .

21. What is the acceleration of the block?
- (A) $\frac{F}{m}$
 (B) $\frac{F \cos \phi}{m}$
 (C) $\frac{F - f}{m}$
 (D) $\frac{F \cos \phi - f}{m}$
 (E) $\frac{F \sin \phi - mg}{m}$
22. What is the coefficient of friction between the block and the surface?
- (A) $\frac{f}{mg}$
 (B) $\frac{mg}{f}$
 (C) $\frac{mg - F \cos \phi}{f}$
 (D) $\frac{f}{mg - F \cos \phi}$
 (E) $\frac{f}{mg - F \sin \phi}$

GO ON TO THE NEXT PAGE

23. This question was not counted when the exam was scored.

24. Two people are initially standing still on frictionless ice. They push on each other so that one person, of mass 120 kg, moves to the left at 2 m/s, while the other person, of mass 80 kg, moves to the right at 3 m/s. What is the velocity of their center of mass?

- (A) Zero
- (B) 0.5 m/s to the left
- (C) 1 m/s to the right
- (D) 2.4 m/s to the left
- (E) 2.5 m/s to the right

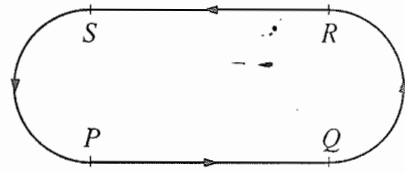

25. A figure of a dancer on a music box moves counterclockwise at constant speed around the path shown above. The path is such that the lengths of its segments, PQ , QR , RS , and SP , are equal. Arcs QR and SP are semicircles. Which of the following best represents the magnitude of the dancer's acceleration as a function of time t during one trip around the path, beginning at point P ?

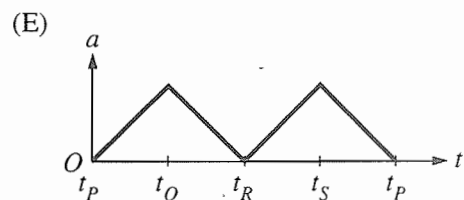
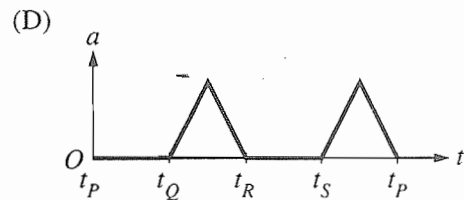
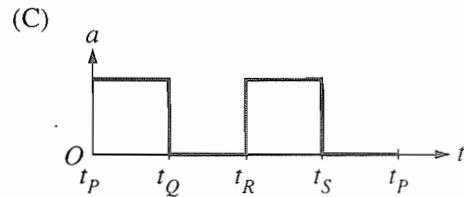
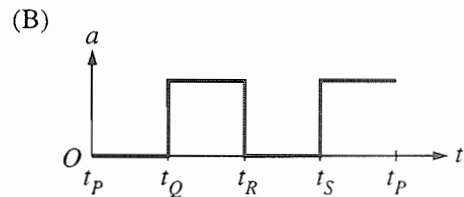
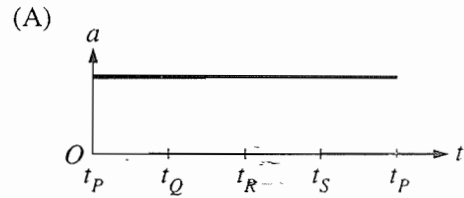

GO ON TO THE NEXT PAGE

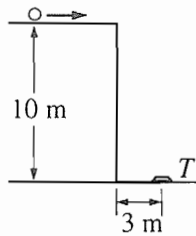

26. A target T lies flat on the ground 3 m from the side of a building that is 10 m tall, as shown above. A student rolls a ball off the horizontal roof of the building in the direction of the target. Air resistance is negligible. The horizontal speed with which the ball must leave the roof if it is to strike the target is most nearly

- (A) $\frac{3}{10}$ m/s
 (B) $\sqrt{2}$ m/s
 (C) $\frac{3}{\sqrt{2}}$ m/s
 (D) 3 m/s
 (E) $10\sqrt{\frac{5}{3}}$ m/s

27. To stretch a certain nonlinear spring by an amount x requires a force F given by $F = 40x - 6x^2$, where F is in newtons and x is in meters. What is the change in potential energy when the spring is stretched 2 meters from its equilibrium position?

- (A) 16 J
 (B) 28 J
 (C) 56 J
 (D) 64 J
 (E) 80 J

28. When a block slides a certain distance down an incline, the work done by gravity is 300 J. What is the work done by gravity if this block slides the same distance up the incline?

- (A) 300 J
 (B) Zero
 (C) -300 J
 (D) It cannot be determined without knowing the distance the block slides.
 (E) It cannot be determined without knowing the coefficient of friction.

29. A particle moves in the xy -plane with coordinates given by

$$x = A \cos \omega t \text{ and } y = A \sin \omega t,$$

where $A = 1.5$ meters and $\omega = 2.0$ radians per second. What is the magnitude of the particle's acceleration?

- (A) Zero
 (B) 1.3 m/s^2
 (C) 3.0 m/s^2
 (D) 4.5 m/s^2
 (E) 6.0 m/s^2

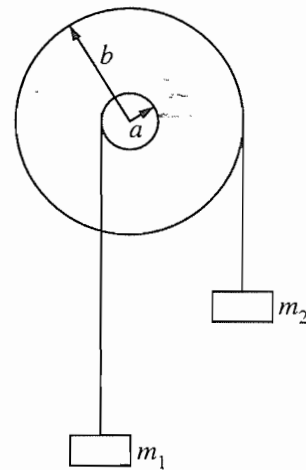

30. For the wheel-and-axle system shown above, which of the following expresses the condition required for the system to be in static equilibrium?

- (A) $m_1 = m_2$
 (B) $am_1 = bm_2$
 (C) $am_2 = bm_1$
 (D) $a^2m_1 = b^2m_2$
 (E) $b^2m_1 = a^2m_2$

GO ON TO THE NEXT PAGE



31. An object having an initial momentum that may be represented by the vector above strikes an object that is initially at rest. Which of the following sets of vectors may represent the momenta of the two objects after the collision?

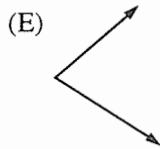
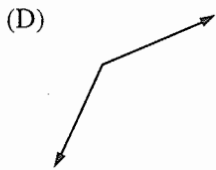
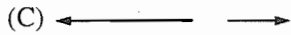

Questions 32-33

A wheel with rotational inertia I is mounted on a fixed, frictionless axle. The angular speed ω of the wheel is increased from zero to ω_f in a time interval T .

32. What is the average net torque on the wheel during this time interval?

(A) $\frac{\omega_f}{T}$

(B) $\frac{\omega_f}{T^2}$

(C) $\frac{I\omega_f^2}{T}$

(D) $\frac{I\omega_f}{T^2}$

(E) $\frac{I\omega_f}{T}$

33. What is the average power input to the wheel during this time interval?

(A) $\frac{I\omega_f}{2T}$

(B) $\frac{I\omega_f^2}{2T}$

(C) $\frac{I\omega_f^2}{2T^2}$

(D) $\frac{I^2\omega_f}{2T^2}$

(E) $\frac{I^2\omega_f^2}{2T^2}$

GO ON TO THE NEXT PAGE

34. An object is released from rest at time $t = 0$ and falls through the air, which exerts a resistive force such that the acceleration a of the object is given by $a = g - bv$, where v is the object's speed and b is a constant. If limiting cases for large and small values of t are considered, which of the following is a possible expression for the speed of the object as an explicit function of time?

- (A) $v = g(1 - e^{-bt})/b$
 (B) $v = (ge^{bt})/b$
 (C) $v = gt - bt^2$
 (D) $v = (g + a)t/b$
 (E) $v = v_0 + gt, v_0 \neq 0$

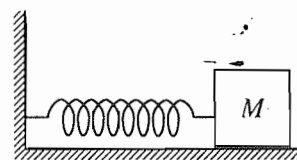

35. An ideal massless spring is fixed to the wall at one end, as shown above. A block of mass M attached to the other end of the spring oscillates with amplitude A on a frictionless, horizontal surface. The maximum speed of the block is v_m . The force constant of the spring is

- (A) $\frac{Mg}{A}$
 (B) $\frac{Mgv_m}{2A}$
 (C) $\frac{Mv_m^2}{2A}$
 (D) $\frac{Mv_m^2}{A^2}$
 (E) $\frac{Mv_m^2}{2A^2}$

STOP

END OF SECTION I, MECHANICS

IF YOU FINISH BEFORE TIME IS CALLED, YOU MAY CHECK YOUR WORK
 ON SECTION I, MECHANICS, ONLY.
 DO NOT TURN TO ANY OTHER TEST MATERIALS.

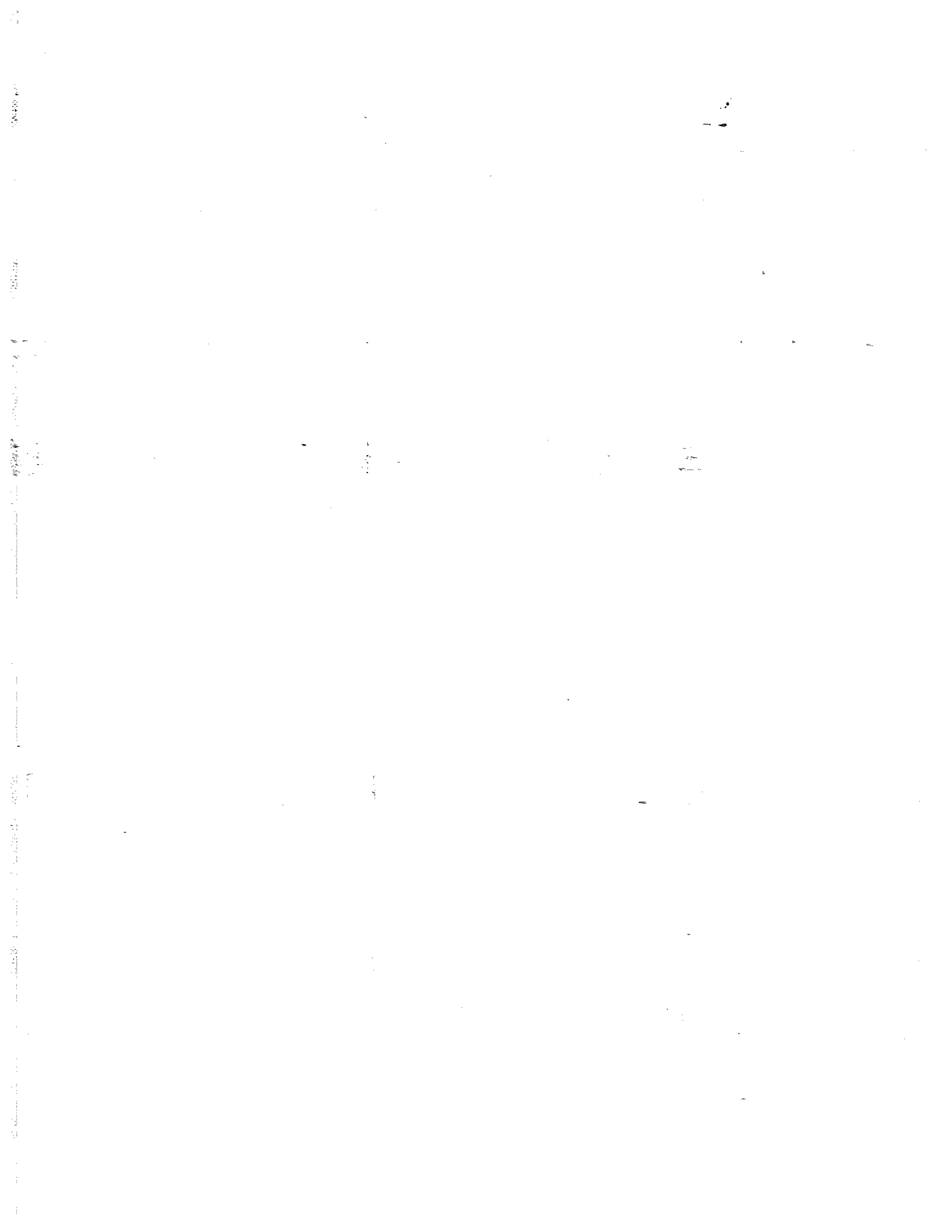

PHYSICS C

SECTION I, ELECTRICITY AND MAGNETISM

Time—45 minutes

35 Questions

Directions: Each of the questions or incomplete statements below is followed by five suggested answers or completions. Select the one that is best in each case and then fill in the corresponding oval on the answer sheet.

36. A resistor R and a capacitor C are connected in series to a battery of terminal voltage V_0 . Which of the following equations relating the current I in the circuit and the charge Q on the capacitor describes this circuit?

- (A) $V_0 + QC - I^2R = 0$
- (B) $V_0 - \frac{Q}{C} - IR = 0$
- (C) $V_0^2 - \frac{1}{2} \frac{Q^2}{C} - I^2R = 0$
- (D) $V_0 - C \frac{dQ}{dt} - I^2R = 0$
- (E) $\frac{Q}{C} - IR = 0$

37. Which of the following combinations of $4\ \Omega$ resistors would dissipate $24\ \text{W}$ when connected to a $12\ \text{V}$ battery?

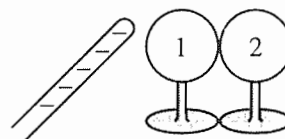
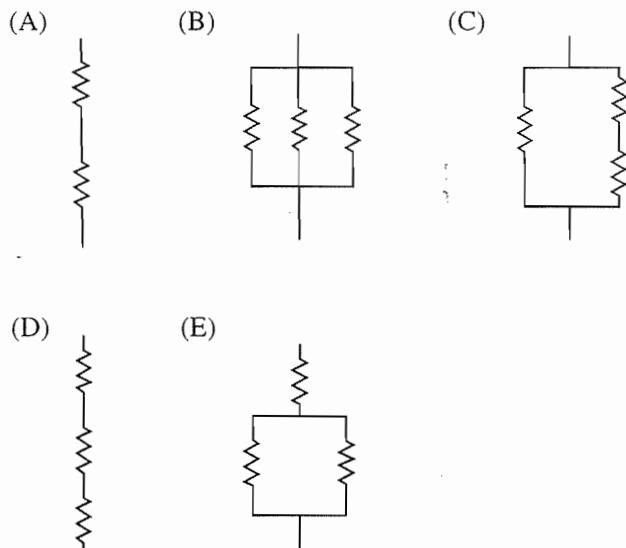

38. Two initially uncharged conductors, 1 and 2, are mounted on insulating stands and are in contact, as shown above. A negatively charged rod is brought near but does not touch them. With the rod held in place, conductor 2 is moved to the right by pushing its stand, so that the conductors are separated.

Which of the following is now true of conductor 2?

- (A) It is uncharged.
- (B) It is positively charged.
- (C) It is negatively charged.
- (D) It is charged, but its sign cannot be predicted.
- (E) It is at the same potential that it was before the charged rod was brought near.

GO ON TO THE NEXT PAGE

Questions 39-40

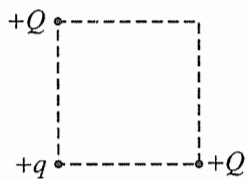

As shown above, two particles, each of charge $+Q$, are fixed at opposite corners of a square that lies in the plane of the page. A positive test charge $+q$ is placed at a third corner.

39. What is the direction of the force on the test charge due to the two other charges?

- (A)
- (B)
- (C)
- (D)
- (E)

40. If F is the magnitude of the force on the test charge due to only one of the other charges, what is the magnitude of the net force acting on the test charge due to both of these charges?

- (A) Zero
- (B) $F/\sqrt{2}$
- (C) F
- (D) $\sqrt{2} F$
- (E) $2 F$

41. Gauss's law provides a convenient way to calculate the electric field outside and near each of the following isolated charged conductors EXCEPT a

- (A) large plate
- (B) sphere
- (C) cube
- (D) long, solid rod
- (E) long, hollow cylinder

42. A wire of resistance R dissipates power P when a current I passes through it. The wire is replaced by another wire with resistance $3R$. The power dissipated by the new wire when the same current passes through it is

- (A) $\frac{P}{9}$
- (B) $\frac{P}{3}$
- (C) P
- (D) $3P$
- (E) $6P$

GO ON TO THE NEXT PAGE

Questions 43-44

A narrow beam of protons produces a current of 1.6×10^{-3} A. There are 10^9 protons in each meter along the beam.

43. Of the following, which is the best estimate of the average speed of the protons in the beam?
- (A) 10^{-15} m/s
 (B) 10^{-12} m/s
 (C) 10^{-7} m/s
 (D) 10^7 m/s
 (E) 10^{12} m/s
44. Which of the following describes the lines of magnetic field in the vicinity of the beam due to the beam's current?
- (A) Concentric circles around the beam
 (B) Parallel to the beam
 (C) Radial and toward the beam
 (D) Radial and away from the beam
 (E) There is no magnetic field.

Questions 45-46 refer to two charges located on the line shown in the figure below, in which the charge at point I is $+3q$ and the charge at point III is $+2q$. Point II is halfway between points I and III.

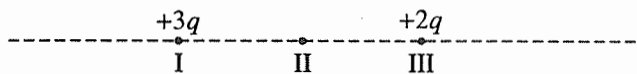

45. Other than at infinity, the electric field strength is zero at a point on the line in which of the following ranges?
- (A) To the left of I
 (B) Between I and II
 (C) Between II and III
 (D) To the right of III
 (E) None; the field is zero only at infinity.
46. The electric potential is negative at some points on the line in which of the following ranges?
- (A) To the left of I
 (B) Between I and II
 (C) Between II and III
 (D) To the right of III
 (E) None; this potential is never negative.

GO ON TO THE NEXT PAGE

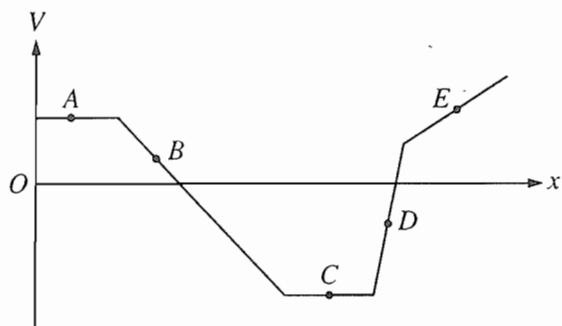

47. The graph above shows the electric potential V in a region of space as a function of position along the x -axis. At which point would a charged particle experience the force of greatest magnitude?

(A) A
(B) B
(C) C
(D) D
(E) E

48. The work that must be done by an external agent to move a point charge of 2 mC from the origin to a point 3 m away is 5 J . What is the potential difference between the two points?

(A) $4 \times 10^{-4} \text{ V}$
(B) 10^{-2} V
(C) $2.5 \times 10^3 \text{ V}$
(D) $2 \times 10^6 \text{ V}$
(E) $6 \times 10^6 \text{ V}$

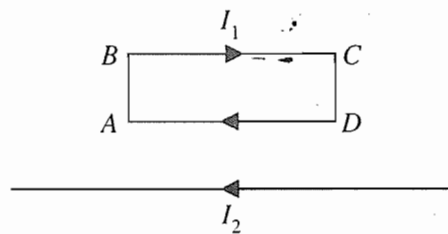

49. A rigid, rectangular wire loop $ABCD$ carrying current I_1 lies in the plane of the page above a very long wire carrying current I_2 , as shown above. The net force on the loop is

(A) toward the wire
(B) away from the wire
(C) toward the left
(D) toward the right
(E) zero

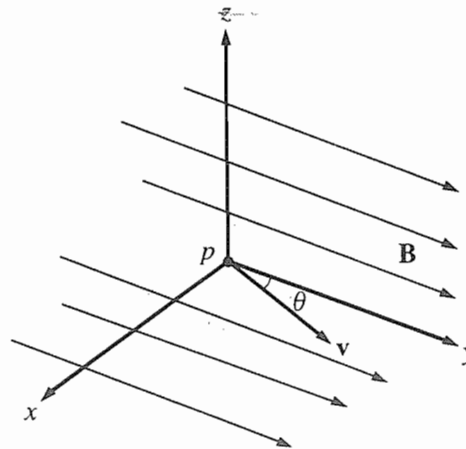

50. A uniform magnetic field \mathbf{B} is parallel to the xy -plane and in the $+y$ -direction, as shown above. A proton p initially moves with velocity \mathbf{v} in the xy -plane at an angle θ to the magnetic field and the y -axis. The proton will subsequently follow what kind of path?

(A) A straight-line path in the direction of \mathbf{v}
(B) A circular path in the xy -plane
(C) A circular path in the yz -plane
(D) A helical path with its axis parallel to the y -axis
(E) A helical path with its axis parallel to the z -axis

GO ON TO THE NEXT PAGE

51. A parallel-plate capacitor has charge $+Q$ on one plate and charge $-Q$ on the other. The plates, each of area A , are a distance d apart and are separated by a vacuum. A single proton of charge $+e$, released from rest at the surface of the positively charged plate, will arrive at the other plate with kinetic energy proportional to

- (A) $\frac{edQ}{A}$
 (B) $\frac{Q^2}{eAd}$
 (C) $\frac{AeQ}{d}$
 (D) $\frac{Q}{ed}$
 (E) $\frac{eQ^2}{Ad}$

52. In which of the following cases does there exist a nonzero magnetic field that can be conveniently determined by using Ampere's law?

- (A) Outside a point charge that is at rest
 (B) Inside a stationary cylinder carrying a uniformly distributed charge
 (C) Inside a very long current-carrying solenoid
 (D) At the center of a current-carrying loop of wire
 (E) Outside a square current-carrying loop of wire

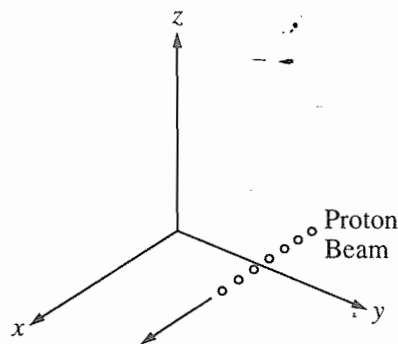

53. A beam of protons moves parallel to the x -axis in the positive x -direction, as shown above, through a region of crossed electric and magnetic fields balanced for zero deflection of the beam. If the magnetic field is pointed in the positive y -direction, in what direction must the electric field be pointed?

- (A) Positive y -direction
 (B) Positive z -direction
 (C) Negative x -direction
 (D) Negative y -direction
 (E) Negative z -direction

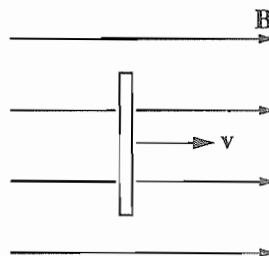

54. A vertical length of copper wire moves to the right with a steady velocity v in the direction of a constant horizontal magnetic field B , as shown above. Which of the following describes the induced charges on the ends of the wire?

- | <u>Top End</u> | <u>Bottom End</u> |
|----------------|-------------------|
| (A) Positive | Negative |
| (B) Negative | Positive |
| (C) Negative | Zero |
| (D) Zero | Negative |
| (E) Zero | Zero |

GO ON TO THE NEXT PAGE

55. Suppose that an electron (charge $-e$) could orbit a proton (charge $+e$) in a circular orbit of constant radius R . Assuming that the proton is stationary and only electrostatic forces act on the particles, which of the following represents the kinetic energy of the two-particle system?

- (A) $\frac{1}{4\pi\epsilon_0} \frac{e}{R}$
 (B) $\frac{1}{8\pi\epsilon_0} \frac{e^2}{R}$
 (C) $-\frac{1}{8\pi\epsilon_0} \frac{e^2}{R}$
 (D) $\frac{1}{4\pi\epsilon_0} \frac{e^2}{R^2}$
 (E) $-\frac{1}{4\pi\epsilon_0} \frac{e^2}{R^2}$

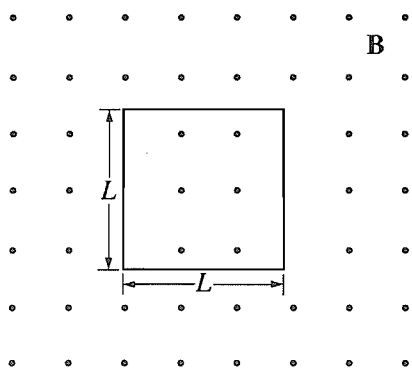

56. A square wire loop with side L and resistance R is held at rest in a uniform magnetic field of magnitude B directed out of the page, as shown above. The field decreases with time t according to the equation $B = a - bt$, where a and b are positive constants. The current I induced in the loop is

- (A) zero
 (B) aL^2/R , clockwise
 (C) aL^2/R , counterclockwise
 (D) bL^2/R , clockwise
 (E) bL^2/R , counterclockwise

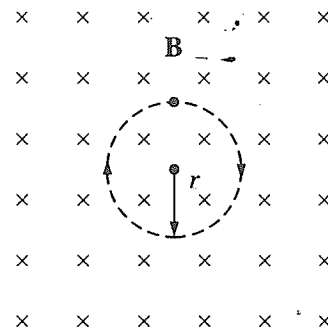

57. A negatively charged particle in a uniform magnetic field \mathbf{B} moves in a circular path of radius r , as shown above. Which of the following graphs best depicts how the frequency of revolution f of the particle depends on the radius r ?

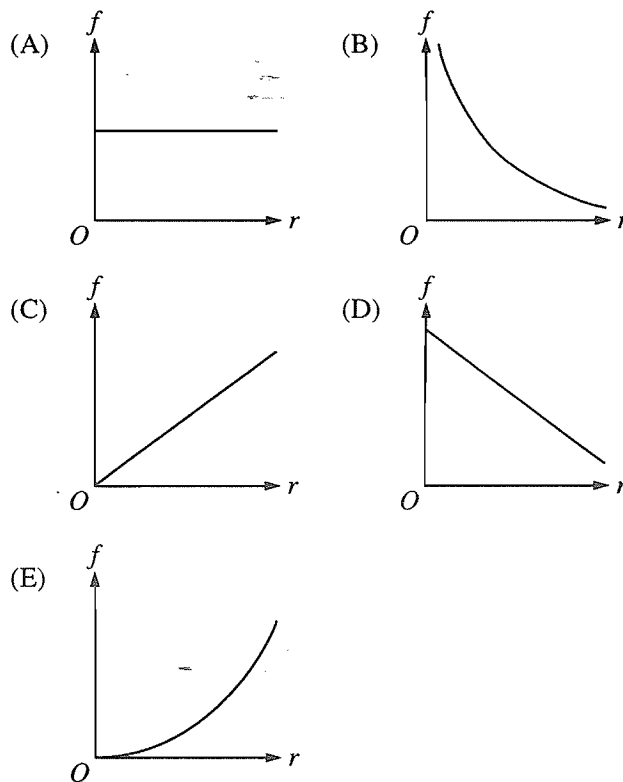

GO ON TO THE NEXT PAGE

58. If the only force acting on an electron is due to a uniform electric field, the electron moves with constant
- (A) acceleration in a direction opposite to that of the field
 - (B) acceleration in the direction of the field
 - (C) acceleration in a direction perpendicular to that of the field
 - (D) speed in a direction opposite to that of the field
 - (E) speed in the direction of the field

Questions 59-60

In a region of space, a spherically symmetric electric potential is given as a function of r , the distance from the origin, by the equation $V(r) = kr^2$, where k is a positive constant.

59. What is the magnitude of the electric field at a point a distance r_0 from the origin?
- (A) Zero
 - (B) kr_0
 - (C) $2kr_0$
 - (D) kr_0^2
 - (E) $\frac{2}{3}kr_0^3$
60. What is the direction of the electric field at a point a distance r_0 from the origin and the direction of the force on an electron placed at this point?

<u>Electric Field</u>	<u>Force on Electron</u>
(A) Toward origin	Toward origin
(B) Toward origin	Away from origin
(C) Away from origin	Toward origin
(D) Away from origin	Away from origin
(E) Undefined, since the field is zero	Undefined, since the force is zero

GO ON TO THE NEXT PAGE 

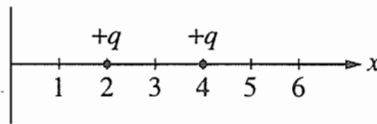

61. Two charged particles, each with a charge of $+q$, are located along the x -axis at $x = 2$ and $x = 4$, as shown above. Which of the following shows the graph of the magnitude of the electric field along the x -axis from the origin to $x = 6$?

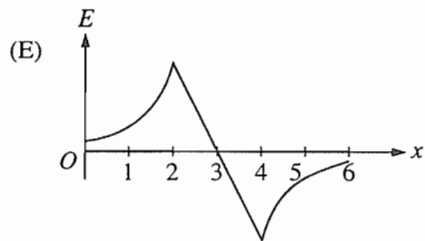
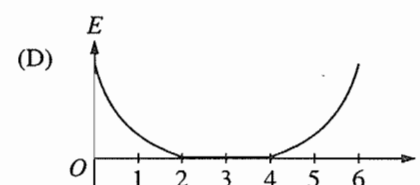
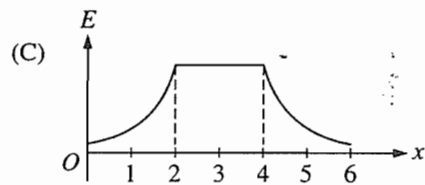
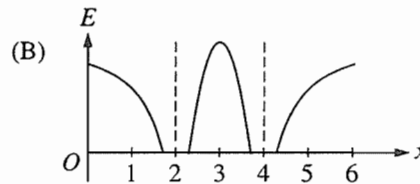
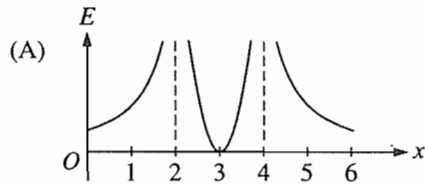

GO ON TO THE NEXT PAGE

62. A positive electric charge is moved at a constant speed between two locations in an electric field, with no work done by or against the field at any time during the motion. This situation can occur only if the
- (A) charge is moved in the direction of the field
 - (B) charge is moved opposite to the direction of the field
 - (C) charge is moved perpendicular to an equipotential line
 - (D) charge is moved along an equipotential line
 - (E) electric field is uniform

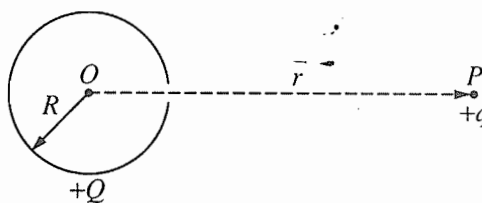

63. The nonconducting hollow sphere of radius R shown above carries a large charge $+Q$, which is uniformly distributed on its surface. There is a small hole in the sphere. A small charge $+q$ is initially located at point P , a distance r from the center of the sphere. If $k = 1/4\pi\epsilon_0$, what is the work that must be done by an external agent in moving the charge $+q$ from P through the hole to the center O of the sphere?
- (A) Zero
 - (B) $\frac{kqQ}{r}$
 - (C) $\frac{kqQ}{R}$
 - (D) $\frac{kq(Q - q)}{r}$
 - (E) $kqQ\left(\frac{1}{R} - \frac{1}{r}\right)$

GO ON TO THE NEXT PAGE

Questions 64-65

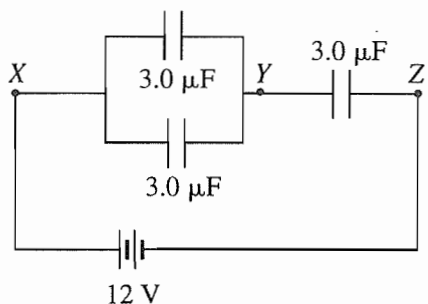

Three identical capacitors, each of capacitance $3.0 \mu\text{F}$, are connected in a circuit with a 12 V battery as shown above.

64. The equivalent capacitance between points X and Z is

(A) $1.0 \mu\text{F}$
 (B) $2.0 \mu\text{F}$
 (C) $4.5 \mu\text{F}$
 (D) $6.0 \mu\text{F}$
 (E) $9.0 \mu\text{F}$

65. The potential difference between points Y and Z is

(A) zero
 (B) 3 V
 (C) 4 V
 (D) 8 V
 (E) 9 V

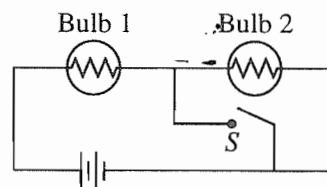

66. The circuit in the figure above contains two identical lightbulbs in series with a battery. At first both bulbs glow with equal brightness. When switch S is closed, which of the following occurs to the bulbs?

Bulb 1	Bulb 2
(A) Goes out	Gets brighter
(B) Gets brighter	Goes out
(C) Gets brighter	Gets slightly dimmer
(D) Gets slightly dimmer	Gets brighter
(E) Nothing	Goes out

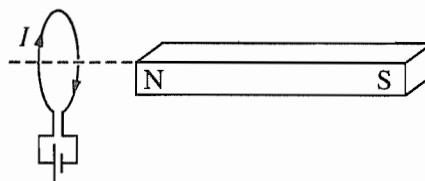

67. A bar magnet and a wire loop carrying current I are arranged as shown above. In which direction, if any, is the force on the current loop due to the magnet?

(A) Toward the magnet
 (B) Away from the magnet
 (C) Toward the top of the page
 (D) Toward the bottom of the page
 (E) There is no force on the current loop.

GO ON TO THE NEXT PAGE

B (into page)

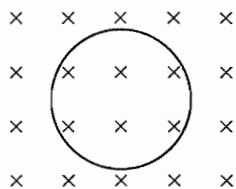

68. A wire loop of area A is placed in a time-varying but spatially uniform magnetic field that is perpendicular to the plane of the loop, as shown above. The induced emf in the loop is given by $\mathcal{E} = bAt^{1/2}$, where b is a constant. The time-varying magnetic field could be given by

- (A) $\frac{1}{2} bAt^{-1/2}$
 (B) $\frac{1}{2} bt^{-1/2}$
 (C) $\frac{1}{2} bt^{1/2}$
 (D) $\frac{2}{3} bAt^{3/2}$
 (E) $\frac{2}{3} bt^{3/2}$

Questions 69-70

A capacitor is constructed of two identical conducting plates parallel to each other and separated by a distance d . The capacitor is charged to a potential difference of V_0 by a battery, which is then disconnected.

69. If any edge effects are negligible, what is the magnitude of the electric field between the plates?

- (A) V_0d
 (B) V_0/d
 (C) d/V_0
 (D) V_0/d^2
 (E) V_0^2/d

70. A sheet of insulating plastic material is inserted between the plates without otherwise disturbing the system. What effect does this have on the capacitance?

- (A) It causes the capacitance to increase.
 (B) It causes the capacitance to decrease.
 (C) None; the capacitance does not change.
 (D) Nothing can be said about the effect without knowing the dielectric constant of the plastic.
 (E) Nothing can be said about the effect without knowing the thickness of the sheet.

STOP

END OF SECTION I, ELECTRICITY AND MAGNETISM

IF YOU FINISH BEFORE TIME IS CALLED, YOU MAY
 CHECK YOUR WORK ON THIS SECTION.

DO NOT GO ON TO SECTION II UNTIL YOU ARE TOLD TO DO SO.

Chapter V

Answers to the 1998 AP Physics C Examination

- Section I: Multiple Choice
 - Blank Answer Sheet
- Section II: Free Response

Section I: Multiple Choice

Listed below are the correct answers to the multiple-choice questions and the percentage of AP candidates who answered each question correctly.

Answer Key and Percent Answering Correctly

Mechanics			Electricity & Magnetism		
Item No.	Correct Answer	Percent Correct	Item No.	Correct Answer	Percent Correct
1	B	82%	36	B	74%
2	E	82%	37	E	65%
3	D	78%	38	C	77%
4	B	67%	39	E	93%
5	C	69%	40	D	79%
6	A	56%	41	C	56%
7	A	56%	42	D	75%
8	D	45%	43	D	29%
9	D	18%	44	A	75%
10	A	53%	45	C	80%
11	E	45%	46	E	61%
12	C	68%	47	D	34%
13	C	81%	48	C	45%
14	B	61%	49	A	49%
15	A	42%	50	D	33%
16	C	54%	51	A	28%
17	A	50%	52	C	45%
18	B	82%	53	E	50%
19	A	35%	54	E	63%
20	B	18%	55	B	26%
21	D	89%	56	E	50%
22	E	42%	57	A	19%
*23	—	—	58	A	53%
24	A	67%	59	C	50%
25	B	56%	60	B	24%
26	C	63%	61	A	74%
27	D	46%	62	D	64%
28	C	59%	63	E	39%
29	E	29%	64	B	71%
30	B	71%	65	D	27%
31	E	48%	66	B	46%
32	E	65%	67	A	24%
33	B	36%	68	E	30%
34	A	37%	69	B	62%
35	D	58%	70	A	61%

*This question was not counted when the exam was scored.